

# Dryer

DA 475  
Gas

## Installation / Maintenance And Part Manual



Revision 1.3

13 / 05 / 2005

B&C Technologies Inc.

Panama City, FL

(850) 249-2222

(850) 249-2226 FAX

[www.bmctechnologies.com](http://www.bmctechnologies.com)

# Table of Contents

## **Section 1**

Important Information	
A. Receiving and Handling	2
B. Safety Precautions	3

## **Section 2**

Specifications/Component Identification	5
A. Specification (Gas and Steam Model)	5
Component Identification	6
Installation Procedures	8
A. Reassembly of Dryer	9
B. Location Requirements	10
C. Fresh Air Supply	11
D. Exhaust Requirements	12
E. Compressed Air Supply	14
F. Electrical Information	15
G. Steam Information	17
H. Preparation For Operation/Start up	23

## **Section 4**

Routine Maintenance	24
A. Cleaning	24
B. Adjustments	26

## **Section 5**

Warranty Information	27
A. Warranty	27
B. Returning Warranty Parts	27

## **Section 6**

Component System Descriptions	28
A. Basket/Tumbler Drive System	28
B. Basket/Tumbler	28
C. Air Blower Drive System	28
D. Safety Devices	29
E. Steam Damper Actuator System	29
F. Drive System Soft Start	31

## **Section 7**

Troubleshooting	37
-----------------	----

## **Section 8**

Part Manual Information	45
-------------------------	----

## SECTION 1 IMPORTANT INFORMATION

### A. RECEIVING AND HANDLING

The dryer is shipped in a protective stretch wrap cover with protective cardboard corners and top cover (or optional box) as a means of preventing damage in transit. Upon delivery, the dryer and/or protective packaging, and wooden skid should be visually inspected for shipping damage. If any damage whatsoever is noticed, inspect further before delivering carrier leaves.

Dryers damaged in shipment:

1. All dryers should be inspected upon receipt and before they are signed for.
2. If there is suspected damage or actual damage, the trucker's receipt should be so noted.
3. If the dryer is damaged beyond repair, it should be refused. Those dryers which were not damaged in a damaged shipment should be accepted, but the number received and number refused must be noted on the receipt.
4. If you determine that the dryer was damaged after the trucker has left your location, you should call the delivering carrier's freight terminal immediately and file a claim. The freight company considers this concealed damage. This type of freight claim is very difficult to get paid and becomes extremely difficult when more than a day or two passes after the freight was delivered. It is your responsibility to file freight claims. Dryers/parts damaged in transit cannot be claimed under warranty.
5. Freight claims are the responsibility of the consignee, and all claims must be filed at the receiving end. Our company assumes no responsibility for freight claims or damages.
6. If you need assistance in handling the situation, please contact our office

**IMPORTANT:** The basket (tumbler) section of the dryer must be transported and handled in an upright position at all times.

## B. SAFETY PRECAUTIONS

**WARNING:** For your safety, the information in this manual must be followed to minimize the risk of fire or explosion or to prevent property damage, personal injury, or loss of life.

1. Do not store or use gasoline or other flammable vapors and liquids in the vicinity of this or any other appliance.
2. Purchaser / user should consult the local gas supplier for proper instructions to be followed in the event the user smells gas. The instructions should be posted in a prominent location.
3. Dryer(s) must be exhausted to the outdoors.
4. Although our company produces a versatile machine, there are some articles that, due to fabric composition or cleaning method, should not be dried in it.

**WARNING:** Dry only water-washed fabrics. Do not dry articles spotted or washed in dry cleaning solvents, a combustible detergent, or "all purpose" cleaner. EXPLOSION COULD RESULT.

**WARNING:** Do not dry rags or articles coated or contaminated with gasoline, kerosene, oil, paint, or wax. EXPLOSION COULD RESULT.

**WARNING:** Do not dry mop heads. Contamination by wax or flammable solvents will create a fire hazard.

**WARNING:** Do not use heat for drying articles that contain plastic, foam, sponge rubber, or similarly textured rubber-like materials. Drying in a heated basket (tumbler) may damage plastics or rubber and also may be a fire hazard.

7. A program should be established for the inspection and cleaning of the lint in the burner area, exhaust ductwork, and inside the dryer. The frequency of inspection and cleaning can best be determined from experience at each location.

**WARNING:** The collection of lint in the burner area and exhaust ductwork can create a potential fire hazard.

5. For personal safety, the dryer must be electrically grounded in accordance with local codes.

**NOTE:** Failure to do so will VOID WARRANTY.

6. Under no circumstances should the dryer door switches, lint drawer switch, or heat circuit safety devices ever be disabled.

**| WARNING:** Personal injury or fire could result.

7. This dryer is not to be used in the presence of dry cleaning solvents or fumes.

8. Remove articles from the dryer as soon as the drying cycle has been completed.

**WARNING:** Articles left in the dryer after the drying and cooling cycles have been completed can create a fire hazard.

9. Do not operate steam dryers with more than 125 PSI steam pressure. Excessive steam pressure can damage steam coil and / or harm personnel.
10. Replace leaking flexible steam hoses or other steam fixtures immediately. Do not operate dryer with leaking flexible hoses. Personal injury may result.
11. Read and follow all caution and direction labels attached to dryer.
12. DO NOT operate steam dryers with more than 125 PSI steam pressure. Excessive steam pressure can damage steam coil and or harm personnel.
13. Replace leaking flexible steam hoses or other steam fixtures immediately. Do not operate dryer with leaking flexible hoses. Personal injury may result.
14. Read and follow All caution and direction labels attached to dryer.

**WARNING:** YOU MUST DISCONNECT and LOCKOUT THE ELECTRIC SUPPLY and THE GAS SUPPLY or THE STEAM SUPPLY BEFORE ANY COVERS or GUARDS ARE REMOVED FROM THE MACHINE TO ALLOW ACCESS DOR CLEANING, ADJUSTING, INSTALLATION, or TESTING OF ANY EQUIPMENT per OSHA (Occupational Safety and Health Administration) STANDARDS.

## SECTION 2

### SPECIFICATIONS / COMPONENT IDENTIFICATION

#### A. SPECIFICATIONS (Gas and Steam Models)

Maximum Capacity (Dry Weight)		500 lbs.	227 kg.
Minimum Capacity (Dry Weight)		450 lbs.	204 kg.
Basket Diameter		70-7/8"	180.00 cm.
Basket Depth		78-3/4"	200.00 cm.
Basket Motor		7.5 HP.	5.5 kw.
Door Opening (Diameter)		48-5/8"w x 48-1/4"h	123.50cm x 122.50cm
Door Sill Height From Floor		44-5/8"	113.40 cm.
Basket Volume		180.10 cu.ft.	5.10 cu. m.
Gas	Voltage Available	208-460v / 3PH. 50/60 Hz	
	Heat Input	2,850,000 Btu/hr	718,188 kcal / hr
	Blower Motor,	25 HP.	18.5 kw.
	Approx. Weight	8,260 lbs.	3,745 kg.
	Airflow	11,000 cfm.	311.5 cmm.
	Gas Inlet Size	2"	5.08 cm
Steam	Voltage Available	208-460v / 3PH. 50/60 Hz	
	Blower Motor	25 HP.	18.5 kw.
	Approx. Weight	8,710 lbs.	3,950 kg
	Heat Input	60 Bhp	
	Airflow	12,000 cfm.	340 cmm.
	Steam Inlet Size	2-1/2"	6.35 cm.
	Steam Return Size	1-1/4"	3.175 cm.
	Operating Steam Pressure	125 PSI max.	8.6 bar
	Compressed Air Volume	16 cf/hr.	0.45 cm/hr.
	80 PSI Compressed Air	1/2" FPT	1.27 cm.
Minimum Duct Diameter	24"	60.96 cm.	

**NOTES:** The factory reserves the right to make changes in specifications at my time, without notice or obligation.

# B. COMPONENT IDENTIFICATION

## B. COMPONENT IDENTIFICATION (Gas Model)

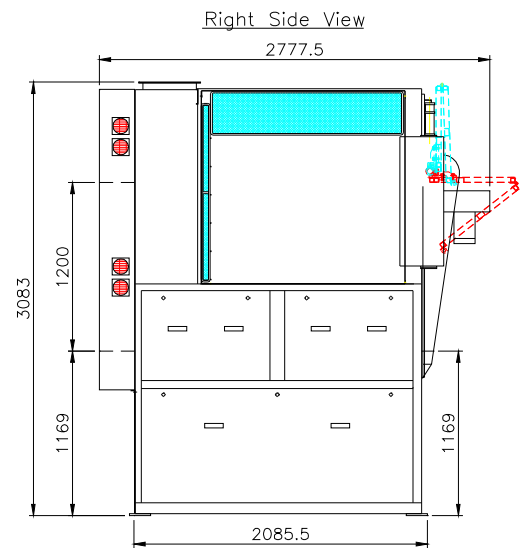
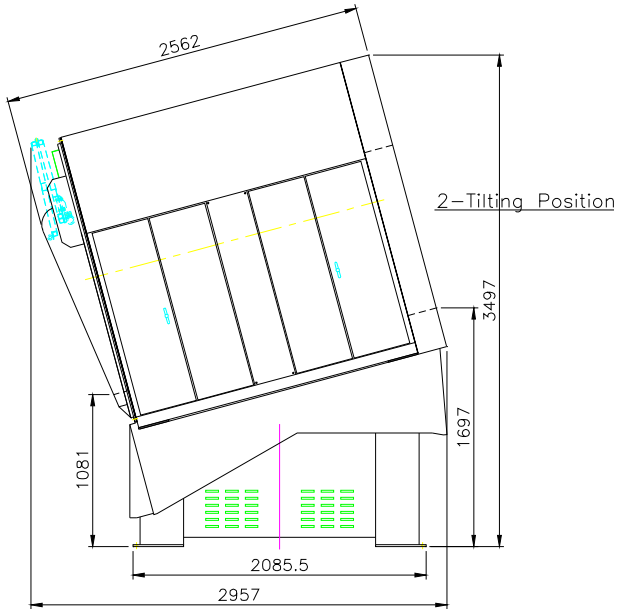
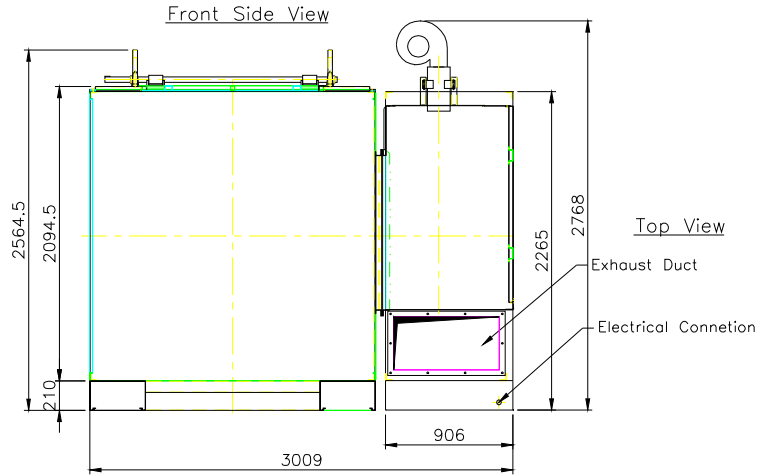
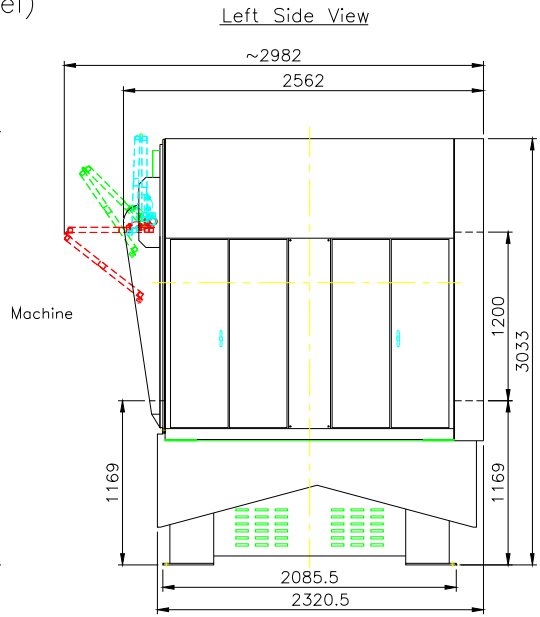
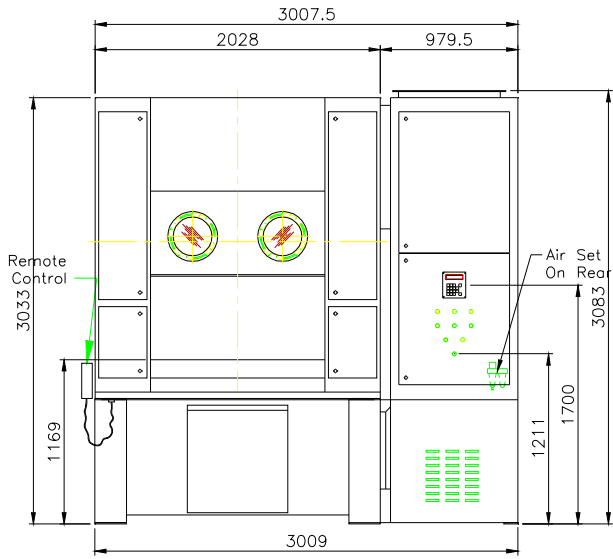

# TUMBLER DRIVE SYSTEM

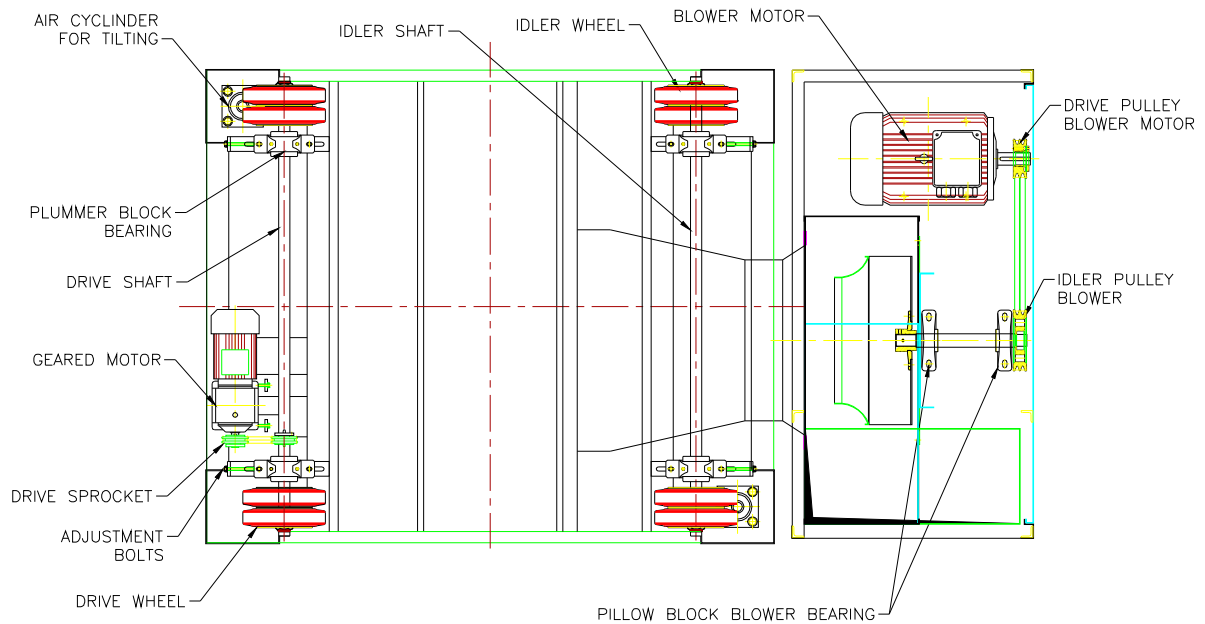

## WHEN REPLACING A DRIVE WHEEL

1. ALWAYS CHANGE BOTH WHEELS ON SHAFT.
2. MARK POSITION OF BEARING ON SUPPORTS THIS WILL MAKE REASSEMBLY OF SHAFT AND CENTERING OF TUMBLER EASIER.
3. SHOVE BLOCKS OF WOOD UNDER TUMBLER TO TAKE IT'S WEIGHT OFF OF DRIVE WHEELS
4. REMOVE BEARING HOLD DOWN BOLTS AND ADJUSTMENT BOLT.
5. IF DRIVE SHAFT IS BEING REMOVED, TAKE OFF DRIVE PULLEY.
6. SLIDE COMPLETE SHAFT ASSEMBLY OUT OF SIDE OF DRYER.



# **SECTION 3**

## **INSTALLATION PROCEDURES**

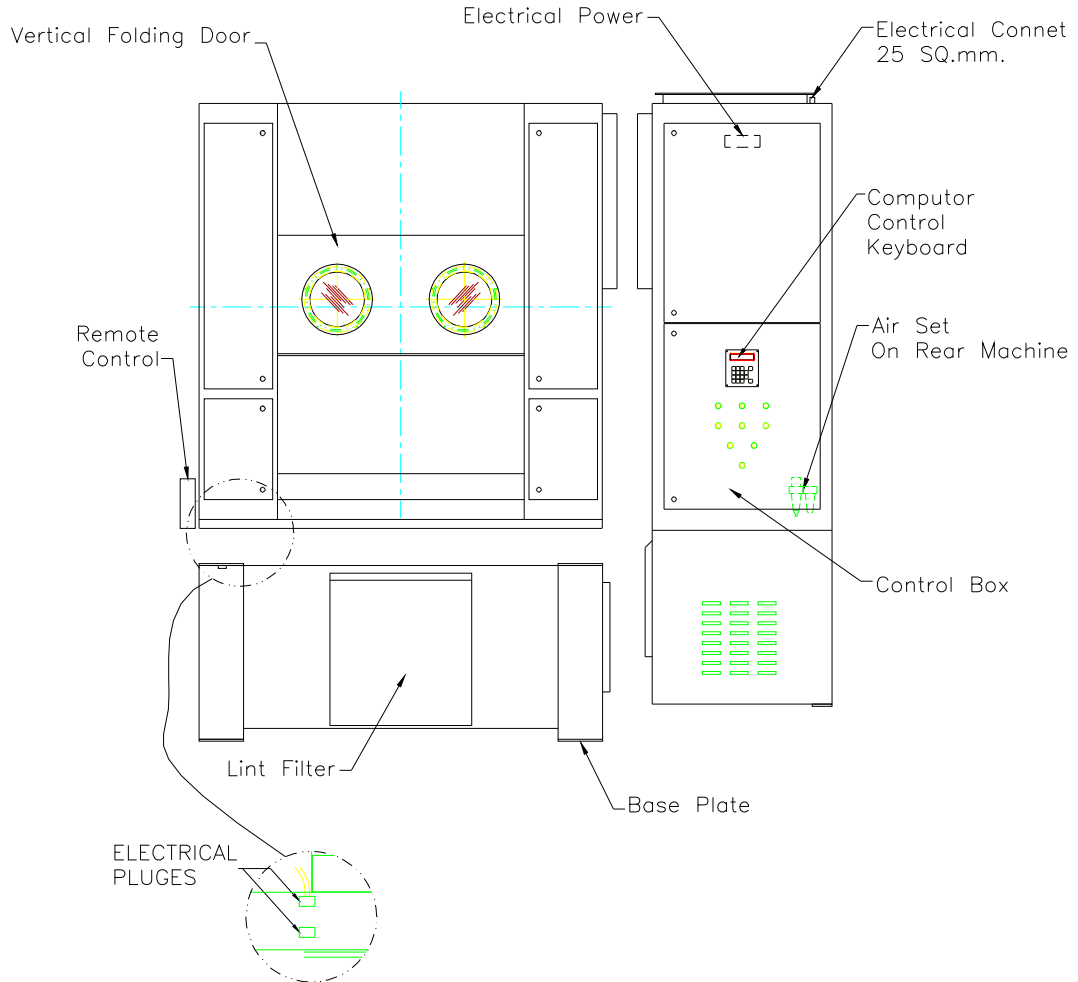

## **INSTALLATION PROCEDURES**

Installation in a proper location should be performed by competent technicians in accordance with local and state codes.

### **A. REASSEMBLY OF DRYER**

**IMPORTANT:** Always keep the basket (tumbler) section of the dryer in an upright position when moving it.

The dryer can be shipped in two (2) ways: as a complete unit fully assembled and ready for hookup or in two (2) pieces with the middle frame separated from the base. At installation, the middle frame will be lifted onto the base. Use cables through the eye bolts on top of the middle frame for lifting. Fasten the middle frame to the base by using the bolts. Also, reconnect the V-belts, belt guard at the rear of the unit, and reconnect the electrical plugs located in the front control boxes.

If the steam coil and damper piston removed, lift the steam connection pipes facing the right side of the unit, and bolt the coil to the top of the middle frame using the #3/8-16 bolts. Also, bolt the damper piston and solenoid valve to the top of the middle frame using the bolts provided. There are three (3) panels that cover the front, right side, and rear of the steam coil. Fasten these panels in position.

1. Reconnect the four (4) pin / socket connectors at the bottom of the right control box.
2. Reconnect the three (3) pin / socket connectors at the bottom of the left control box.
3. Reconnect the two (2) pin / socket connectors within the left control box.
4. Rewire the drive motor by inserting the three (3) black wires into the T1, T2, and T3 connections of the soft start.
5. Rewire the blower (impellor/fan) motor by inserting the three (3) blue wires into the T1, T2 and T3 connections of the telemecanique blower contactor.

## **B. LOCATION REQUIREMENTS**

The model DA-475 dryer requires 20-inches and 20-inches of space on each side of the dryer and 24-inches of space behind the unit for ease of maintenance. A minimum of 20-inches **must be** allowed between the top of machine dryer the ceiling The dryer **must be** leveled for proper operation. If shimming is required put metal shims, which are the same size as the base feet under the base feet. The dryer must be lagged to the floor.

**IMPORTANT:** Dryer should be located where a minimum amount of exhaust duct will be necessary.

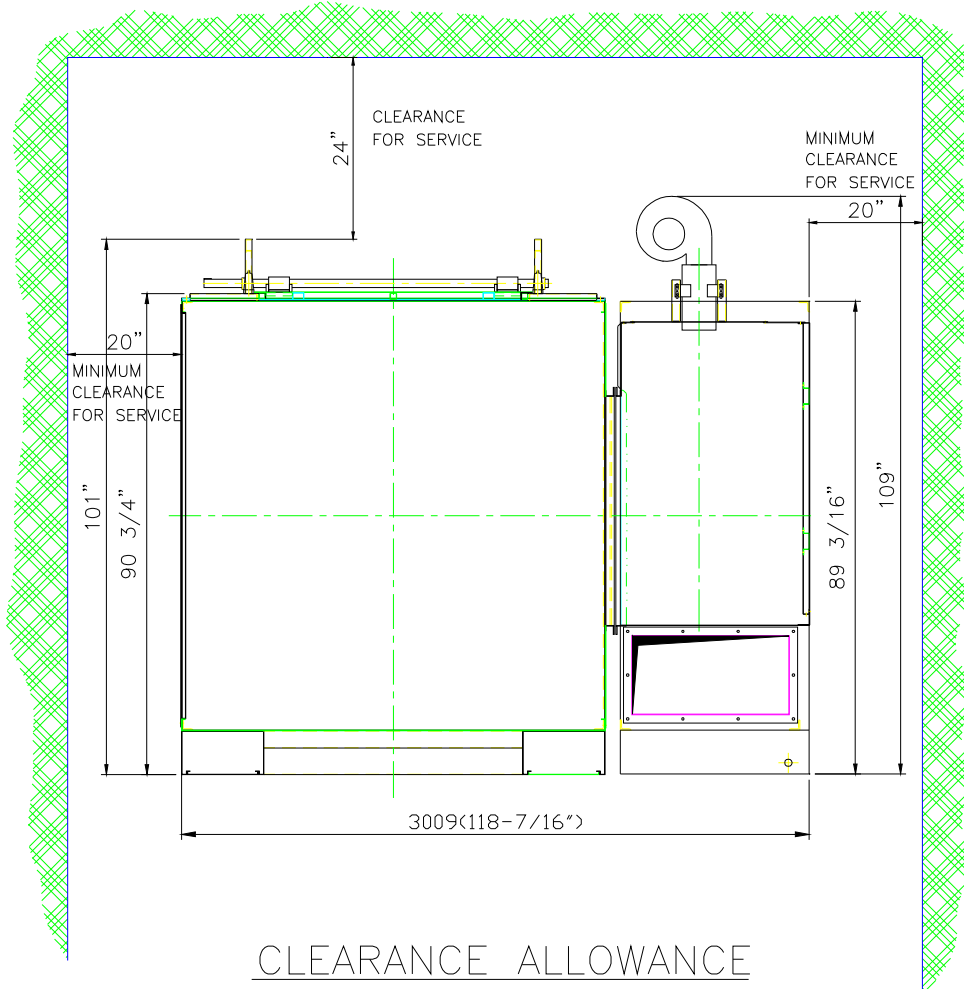

### **C. FRESH AIR SUPPLY**

When the dryer is operating, it draws in room air, heats it, passes this air through the basket (tumbler), and exhausts it out of the building. Therefore, the room air must be continually replenished from the outdoors. If the make-up air is inadequate, drying time and drying efficiency will be adversely affected. Ignition problem and sail switch “fluttering” problems may result, as well as premature motor failure from overheating.

Air supply (make-up air) must be given careful consideration to assure proper performance of each dryer. An unrestricted source of air is necessary for each dryer. An airflow must be supplied to each dryer as specified in specification. As a general rule, an unrestricted air entrance from the outdoors (atmosphere) of a minimum of five (5) square feet is required for each gas dryer and a minimum of six (6) square feet is required for each steam dryer.

To compensate for the use of registers or louver used over the opening, this make-up air area must be increased by approximately thirty-three (33) percent. Make-up air openings should not be located in an area directly near where exhaust vents exit the building.

It is not necessary to have a separate make-up air opening for each dryer. Common make up air openings are acceptable. However, they must be set up in such a manner that the make-up air is distributed equally to all the dryers.

Allowances must be made for remote or constricting passageways or where dryers are located at excessive altitudes or predominantly low pressure areas.

**IMPORTANT:** Make-up air must be provided from a source free of dry cleaning solvent fumes. Make-up air that is contaminated by dry cleaning solvent fumes will result in irreparable damage to motors and other dryer components.

**NOTE:** Component failure due to dry cleaning solvent fumes VOIDS WARRANTY.

## D. EXHAUST REQUIREMENTS

### 1. General Exhaust Duct Work Information

Exhaust duct work should be designed and installed by a qualified professional. Improperly sized duct work will create excessive back pressure which results in slow drying, increased use of energy, over-heating of the dryer, and shutdown of the burner by the airflow (sail) switches, burner hi-limits, or basket (tumbler) hi-heat thermostats.

The duct work should be laid out in such a way that the duct work travels as directly as possible to the outdoors with as few turns as possible. Single or independent dryer venting is recommended.

The internal dimensions of the dryer's rectangular exhaust vent work is 16.8-inches by 28.2-inches (42.7 cm. x 71.5 cm.). The plant's exhaust duct must be at least 16.8-inches (42.7 cm) in diameter or for a rectangular duct have cross-sectional areas of 473.76 square inches (3,053 sq.cm.). The duct work from the dryer to the outside exhaust outlet should not exceed thirty (30) feet. The shape of the duct work is not critical so long as the minimum cross-sectional area is provided. It is suggested that the use of 90° turns in ducting be avoided; use 45° angles instead. The radius of the elbows should preferably be 1-1/2 times the width or diameter of the duct. Excluding basket/dryer elbow connections used for outside protection from the weather, no more than two (2) elbows should be used in the exhaust duct run. If more than two (2) elbows are used, the cross section area of the duct work must be increased.

All duct work should be smooth inside with no projections from sheet metal screws or other obstruction which will collect lint. When adding ducts, the duct to be added should overlap the duct to which it is to be connected. All duct work joints must be taped to prevent moisture and lint from escaping into the building. Inspection doors should be installed at strategic points in the exhaust duct work for periodic inspection and clean out of lint from the duct work.

**IMPORTANT:** Exhaust back pressure measured by a manometer in the exhaust duct should not exceed 0.3 inches of water column.

**NOTE:** Where the exhaust duct work passes through a wall, ceiling or roof made of combustible materials, the opening must be 2 inches larger (all the way around) than the duct. The duct must be centered within this opening.

## Outside Duct Work Protection

To protect the outside end of horizontal duct work from the weather, a 90° elbow bent downward should be installed where the exhaust exits the building. If the duct work travels vertically up through the roof, it should be protected from the weather by using a 180° turn to point the opening downward. In either case, allow at least twice the diameter of the duct between the duct opening and the nearest obstruction.

**IMPORTANT:** Do not use screens or caps on the outside of opening of exhaust duct work.

VERTICAL DUCTING

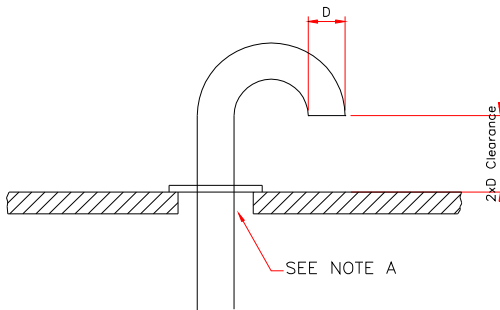

HORIZONTAL DUCTING

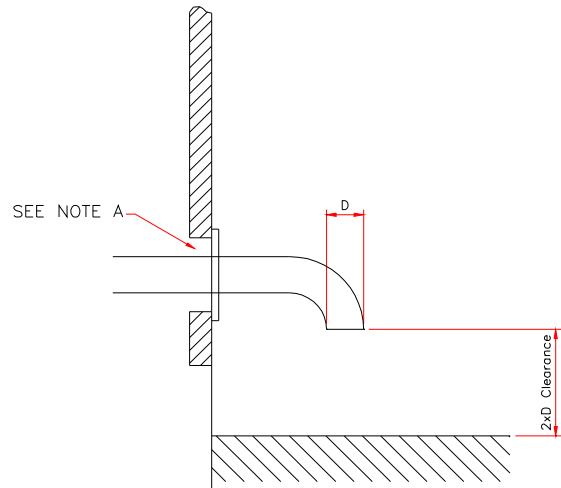

NOTE "A": OPENING MUST BE TWO (2) INCHES LARGER THAN DUCT (ALL THE WAY AROUND). THE DUCT MUST BE CENTERED WITHIN THIS OPENING

## E. COMPRESSED AIR SUPPLY

A clean, dry, regulated supply of 80 psi compressed air **must be** supplied to the dryer. The connection size is 1/2-inch N.P.T. No air filtering or pressures regulating devices are provided with the dryer.

1.GAS DRYERS: The air line supply connection is made into the 1/2-inch N.P.T. port on the air jet solenoid valve which located in the base of the dryer (see illustration below)

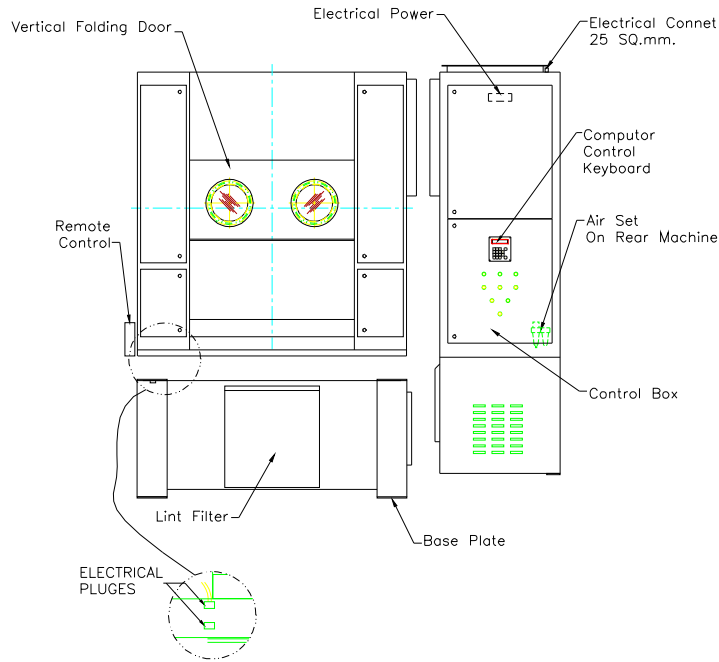

2.STEAM DRYERS: The air line supply connection is made into the 1/2-inch N.P.T. tee which located in the base of the dryer (see illustration below)

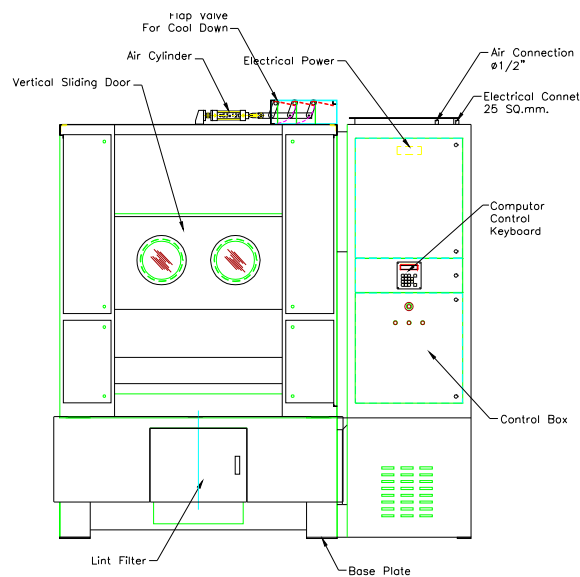

## **F. ELECTRICAL INFORMATION**

### **1. Electrical Requirements**

It is your responsibility to have all electrical connections made by a properly licensed and competent electrician to assure that the electrical installation is adequate and conforms with local and state regulations or codes. In the absence of such codes, all electrical connections, material, and workmanship must conform to the applicable requirements of the national electrical code ANSI/NEPA NO. 70-latest edition.

**IMPORTANT:** Failure to comply with these codes or ordinances, and/or the requirements stipulated in this manual can result in personal injury or component failure.

**NOTE:** Component failure due to improper installation will VOID WARRANTY.

Each dryer should be connected to an independently protected branch circuit. The dryer must be connected with copper wire only. Do not use aluminum wire, which could cause a fire hazard. The copper conductor wire/cable must be of proper ampacity and insulation in accordance with electric codes for making all service connections.

**NOTE:** The use of aluminum wire will VOID WARRANTY.

### **2. Electrical Service Specifications**

#### DA-475, 20Hp Blower, Reversing, 3Ø Motor

Electrical Service Specifications (Per Dryer)						
<p><b>NOTES:</b> A. Fuse ratings are dual element-time delay-current limiting, class RK1 or RK5 ONLY.            B. Circuit breakers are thermal magnetic (industrial) type <b>ONLY</b>. For others, calculate / verify correct breaker size according to appliance amp draw rating and type of breaker used.            C. Circuit breakers for 3Ø dryers <b>must be</b> 3-pole type.</p>						
SERVICE VOLTAGE	PHASE	WIRE SERVICE	APPROX. AMP DRAW	MINIMUM WIRE SIZE*	FUSING	CIRCUIT BREAKER
					Dual Element Time Delay	
208	3Ø	3/4	87	8	125	125
380	3Ø	3/4	48	6	60	90
416	3Ø	3/4	44	6	60	90

\* AWG Stranded Type Wire...for individual lengths longer than 100 feet.

The factory reserves the right to make changes in specifications at any time, without notice or obligation.



### 3. ELECTRICAL CONNECTIONS

**NOTE:** A wiring diagram is included with each dryer and is affixed to the panel inside the right side control cabinet.

The only electrical input connections to the dryer are the 3-phase (3 $\phi$ ) power leads (L1, L2 and L3), GROUND, and in the case of 4 wire service, the neutral. These electrical connections are made at the power distribution block located in the left side control cabinet.

Providing local codes permit, power connections to the dryer can be made by the use of a flexible Underwriters Laboratory listed chord / pigtail (wire size **must conform** to rating of the dryer), or the dryer can be hard wired directly to the service breaker. In **All** cases, a strain relief must be used where the wire(s) enter the dryer electrical service (relay) box.

**NOTE:** A CIRCUIT SERVING EACH DRYER MUST BE PROVIDED.

### 4. GROUNDING

Grounding (earth) connections must be provided and installed in accordance with state and local codes. In the absence of these codes, grounding must conform to applicable requirements of the National Electric Code ANSI/NFPA NO. 70-latest edition. The ground connection may be to a proven earth ground at the location service panel.

**NOTE:** A grounding connection (terminal lug) is provided in the dryer at the left side control cabinet.

For added personal safety, when possible, it is suggested that a separate ground wire (sized per local codes) be connected from the ground connection of the dryer to a grounded cold water pipe. Do not ground to a gas or hot water pipe. The grounded cold water pipe must have metal to metal connections all the way to electrical ground. If there are any non-metallic interruptions, such as a meter, pump, plastic, rubber, or other insulating connectors, they must be jumped out with no.4 copper wire and securely clamped to bare metal at both ends.

**IMPORTANT:** For personal safety and proper operation, the dryer must be grounded. For proper operation of the microprocessor (computer), an earth (zero) ground is required.

**NOTE:** Grounding via metallic electrical conduit (pipe) **is not** commended.

## G. STEAM INFORMATION

It is your responsibility to have **All** steam plumbing connections made by a qualified professional to assure that the installation is adequate and conforms with local and state regulations or codes.

**IMPORTANT:** Failure to comply with the requirements stipulated in the manual can result in component failure, which will **VOID THE WARRANTY.**

**NOTE:** The DA-475 is manufactured with a pneumatic (piston) damper system, which requires an external supply of air (80 psi +/- 10 psi). See Steam Damper Air System Connections Section H item 3.

### 1. STEAM REQUIREMENTS, High Pressure

A. Inlet ---- 2-1/2"inch supply line connection.

B. Return --- 1-1/4"inch return line connection.

Operating Steam Pressure, High Pressure		
Maximum	125 psig	8.79 kg/sq cm
Minimum	100 psig	7.03 kg/sq cm
Heat Input (Normal Load)	60 Bhp	
Consumption (Approximate)	1,367 lbs/hr	~620 kg/hr

### 2. INSTALLATION INSTRUCTIONS

To insure that an adequate supply of steam is provided, be sure that the steam return lines are sized and laid out as stipulated in this manual. Inadequate steam and steam return lines or improper steam plumbing will result in poor performance and can cause component failure. Clean, dry steam **must be** provided to the dryer.

**IMPORTANT:** Steam coil failure due to water hammer by wet steam **VOIDS WARRANTY.**

- A. The pressure of the condensate in the steam supply will cause water hammer and subsequent heat exchanger (steam coil) failure. The steam supply connection into the main supply line **must be** made with a minimum 10-inch riser. This will prevent any condensate from draining towards the dryer.
- B. The steam supply piping to the dryer **must include** a 12-inch rise along with a drip trap and check valve. This will prevent any condensate from entering the steam coil.
- C. Flexible hoses or couplings **must be** used. The dryer vibrates slightly when it runs and this will cause the steam coil connections to crack if they are hard piped to the supply and return mains.
- D. Shut-off valves for each dryer **should be** installed in the supply, return, and drip trap return lines. This will allow the dryer to be isolated from the supply and return mains if the dryer needs maintenance work.

- E. Install an inverted bucket steam trap and check valve at least 12 inches below steam coil as close to the coil as possible.
- F. A vacuum breaker **should be** installed in the piping. This will prevent the condensing steam from causing a vacuum inside the coil and possibly damaging the coil.
- G. The supply and return lines **should be** insulated. This will save energy and provide for the safety of the operator and maintenance personnel.
- H. Water pocket in the supply line, caused by low point, will provide wet steam to the coil possibly causing coil damage. **All** horizontal runs of steam supply piping should be pitched 1/4-inch for every one (1) foot back towards the steam supply header causing any condensate in the line to drain to the header. Install a bypass trap in any low point to eliminate wet steam.

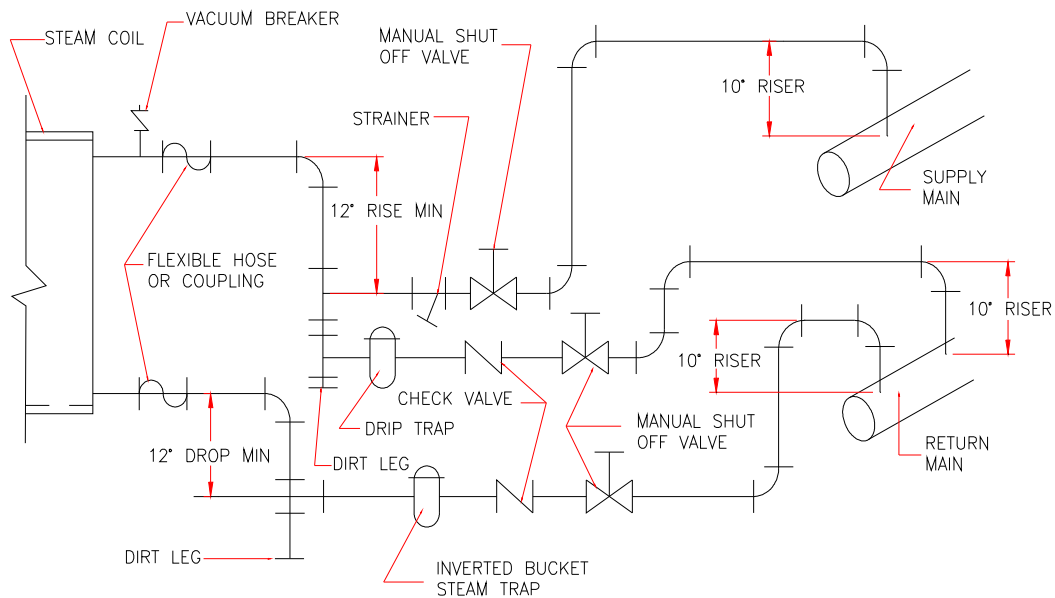

STEAM DAMPER SYSTEM



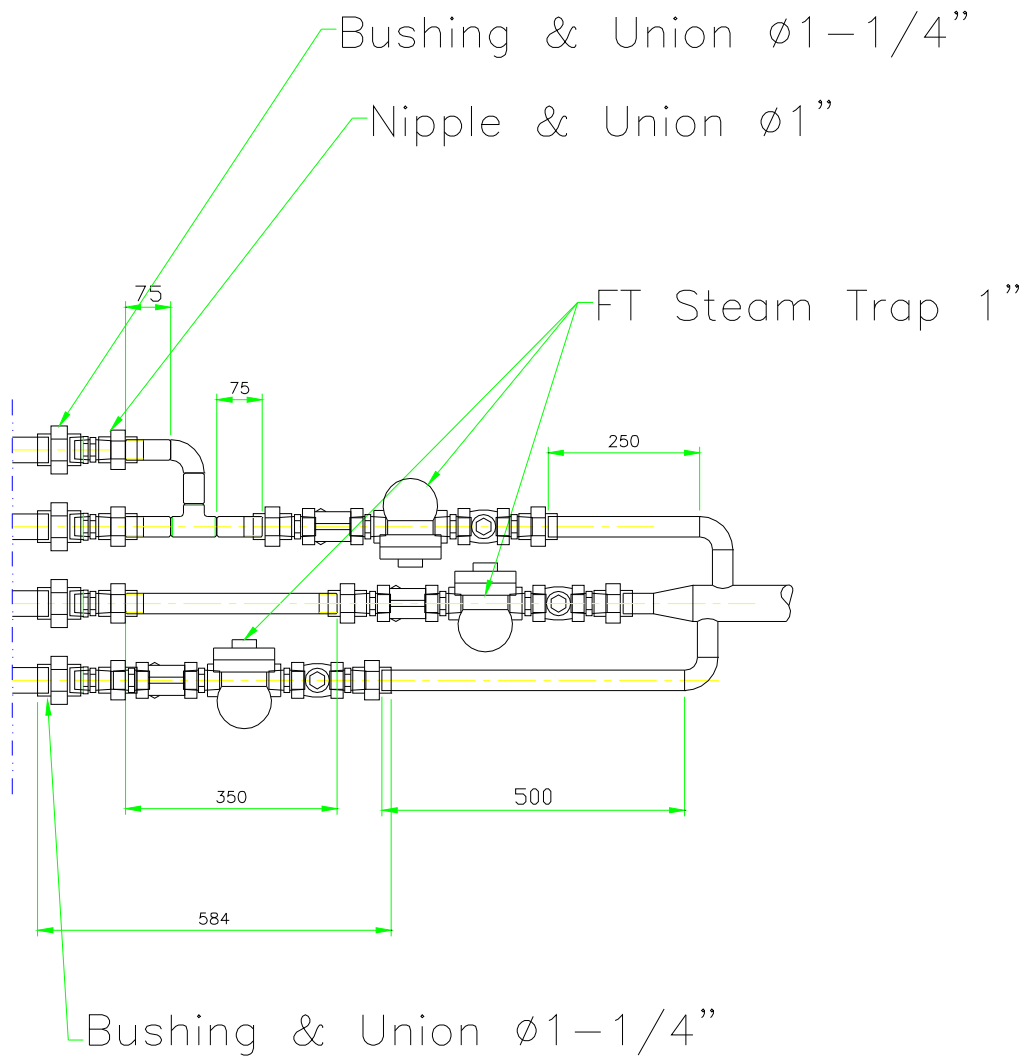

Steam System

### 3. STEAM DAMPER AIR SYSTEM CONNECTIONS

The DA-475 is manufactured with a pneumatic (piston) damper system, which requires an external supply of compressed air. The air connection is made to the steam damper solenoid valve which is located on the outer top, at the rear left hand corner of the dryer.

#### A. AIR REQUIREMENTS

Compressed Air Supply	Air Pressure
Normal	80 psi
Minimum Supply	70 psi
Maximum Supply	90 psi

#### B. AIR CONNECTION

Air connection to system --- 1/2 -inch N.P.T.

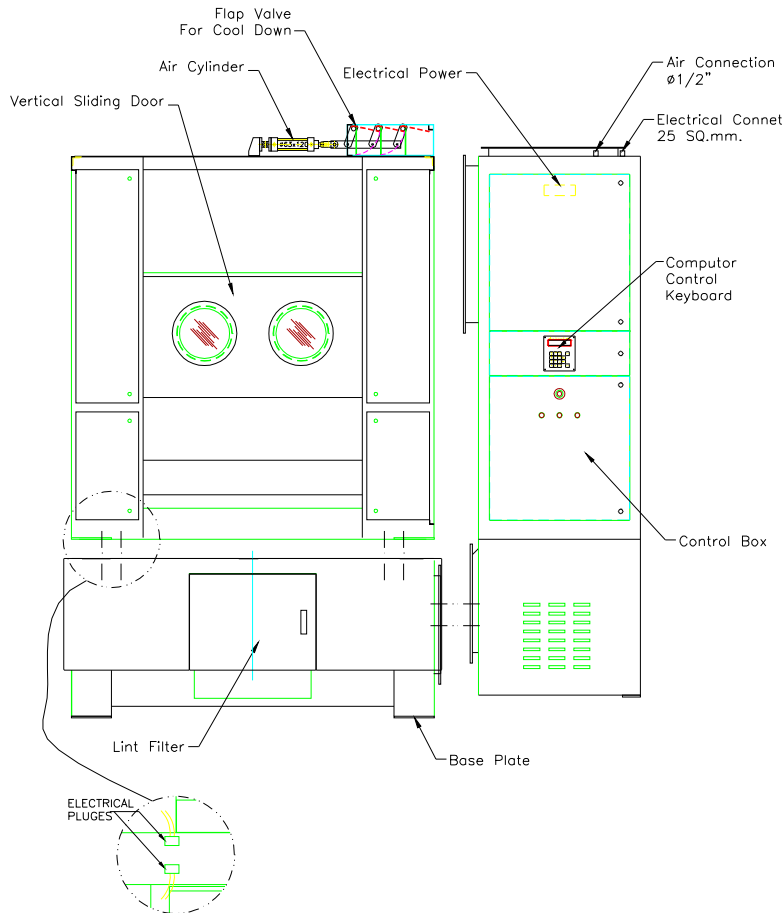

C. No air regulation is provided with the dryer. External regulation of 80 psi must be provided. It is suggested that a regulator/fitter gauge arrangement be added to the compressed air line just before the dryer connection. This is necessary to insure that correct and clean air pressure is achieved.

#### 4. STEAM DAMPER SYSTEM OPERATION

The DA-475 Steam damper allows the coil to stay constantly charged eliminating repeated expansion and contraction. When the damper is opened, the air immediately passes through the already hot coil, providing instant heat to start the drying process. When the damper is closed, ambient air is drawn directly into the basket (tumbler), allowing a rapid cool down.

Diagram 1 shows the damper in the heating (open) mode, allowing heat into the basket (tumbler).

Diagram 2 shows the damper in the cool (closed) mode, pulling ambient air directly into the basket (tumbler) without passing through the coils.

**NOTE:** With the dryer off or with no air supply, the damper is in the cool down mode.

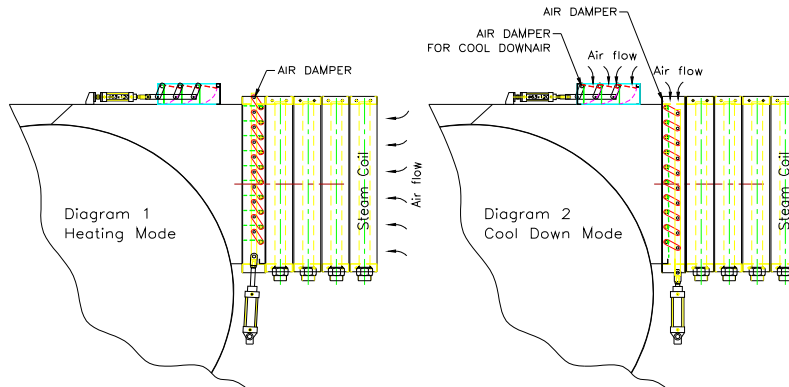

#### 5. STEAM DAMPER AIR CYLINDER (FLOW CONTROL) OPERATION ADJUSTMENT

Damper operation was tested and adjusted prior to shipping at 80 psi. If damper air adjustment is necessary, locate flow control valve and make necessary adjustments.

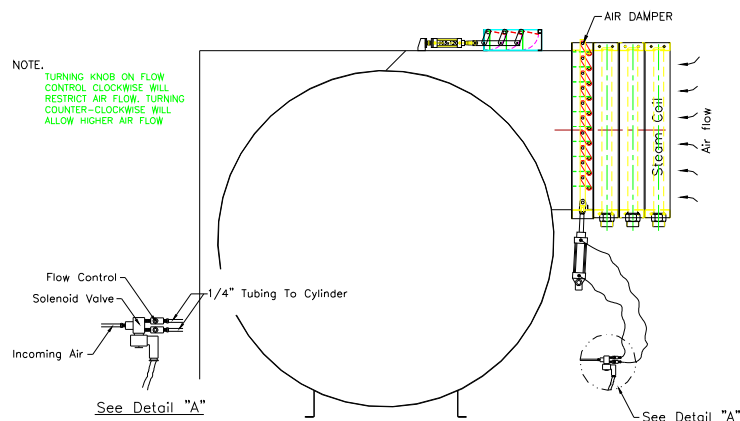

## **H. PREPARATION FOR OPERATION/START-UP**

The following items should be checked before attempting to operate the dryer:

1. Read and follow **All** “**caution**”, “**warning**” and “**direction**” labels attached to the dryer.
2. Check incoming supply voltage to be sure that it is the same as indicated on the dryer data label affixed behind the right control box door. In the case of 208 VAC or 230/240 VAC, the supply voltage **must match** the electric service **exactly**.
3. Check to be sure drive belts between idler pulley and motor pulley have been re-connected.

| **NOTE:** The drive belts were disconnected at factory prior to shipment.

4. Be sure **All** side and base panels and the belt guard are on the dryer.
5. Check **All** service doors to assure that they are closed and secured in place.
6. Be sure the lint drawer is securely in place.

| **NOTE:** Lint drawer **must be** all the way in place to activate safety switch otherwise the dryer will not start.

10. Rotate the basket (tumbler/drum) by hand to be sure it moves freely.
11. Check bolts, nuts, screws, terminals, and fittings for security.
12. Check to insure air supply (80 psi) is connected to dryer.
13. STEAM - check to insure **All** steam shut-off valves are open.



## SECTION 4

### ROUTINE MAINTENANCE

#### A. CLEANING

A program and/or schedule **should be** established for periodic inspection, cleaning and removal of lint from various areas of the dryer, as well as throughout the duct work system. The frequency of cleaning can best be determined from experience at each location. Maximum operating efficiency is dependent upon proper air circulation. The accumulation of lint can restrict this air flow. If the guidelines in this section are met, a dryer will provide many years of efficient, trouble-free, and — most importantly — safe operation.

**WARNING:** LINT FROM MOST FABRICS IS HIGHLY COMBUSTIBLE.  
THE ACCUMULATION OF LINT CAN CREATE A  
POTENTIAL FIRE HAZARD.

**WARNING:** KEEP DRYER AREA CLEAR AND FREE FROM  
COMBUSTIBLE MATERIALS, GASOLINE, AND OTHER  
FLAMMABLE VAPORS AND LIQUIDS.

**NOTE:** Suggested time intervals shown are for average usage which is  
considered six (6) to eight (8) operational (running) hours per day.

#### SUGGESTED CLEANING SCHEDULE

##### AFTER EVERY LOAD

Clean the lint basket. A clogged lint basket will cause poor dryer performance. The lint basket is located in the lint drawer in the base of the dryer. Pull out the lint drawer, brush the lint off the lint basket, and remove the lint. Inspect lint screen and replace if torn.

##### WEEKLY

Open the hinged panels on each side of the basket (tumbler) section and remove any lint accumulation.

Slide the lint basket all the way out of the dryer and clean any lint accumulation off the temperature sensor bracket, which is located above the lint basket.

**WARNING:** TO AVOID THE HAZARD OF ELECTRICAL SHOCK,  
DISCONTINUE ELECTRICAL SUPPLY TO THE DRYER.

## STEAM DRYERS ONLY

Clean the steam coil lint screen located on top of the steam coil. (This may have to be done more frequently.)

### MONTHLY

Apply a high-temperature grease to the four (4) 50 mm. diameter tumbler drive shaft plunger block bearings. Use Shell Alvania # 3 grease or equivalent.

Retighten set screws in the collars of the four (4) 50 mm. diameter tumbler drive shaft bearings.

Apply a high-temperature grease to the two (2) 55 mm. diameter blower drive shaft pillow block bearings. Use Shell Alvania # 3 grease or equivalent.

### EVERY 6 MONTHS

Grease the eight (8) bearings of guide roller located in the dryer's Use Shell Alvania # 3 grease or equivalent.

Check Roller Chain of Gear motor for tightness and wear. Retighten or replace if required.

On steam dryers, clean steam coil fins. We suggest using compressed air and a vacuum cleaner with brush attachment.

**NOTE:** When cleaning steam coil fins, be careful not to bend the fins. If fins are bent, straighten by using fin comb which is available from local air-conditioning supply houses.

Inspect and remove lint accumulation in customer furnished exhaust duct work system and from dryers internal exhaust ducting.

**WARNING:** THE ACCUMULATION OF LINT IN THE EXHAUST DUCT WORK CAN CREATE A POTENTIAL FIRE HAZARD.

**WARNING:** DO NOT OBSTRUCT THE FLOW OF COMBUSTION AND VENTILATION AIR. CHECK CUSTOMER-FURNISHED BACK DRAFT DAMPERS IN EXHAUST DUCT WORK. INSPECT AND REMOVE ANY LINT ACCUMULATION WHICH CAN CAUSE DAMPER TO BIND OR STICK.

**NOTE:** A back draft damper that is sticking partially closed can result in slow drying and shutdown of the heat circuit safety switches or thermostats.

**NOTE:** When cleaning dryer cabinet(s), avoid using harsh abrasives. A product intended for the cleaning of appliances is recommended.

## B. ADJUSTMENTS

### 7 DAYS AFTER INSTALLATION AND EVERY 6 MONTHS THEREAFTER

Inspect bolts, nuts, screws (bearing set screws), non-permanent gas connections (unions, shut-off valves, orifices, and grounding connections).

Motor and drive belts **should be** examined. Cracked or operational check of controls and valves.

Complete operational check of **All** safety devices (door switches, lint drawer switch, sail switch, burner and hi-limit thermostats).

## C. LUBRICATION

The motor bearings, idler bearings, and tumbler bearings are permanently Lubricated, **NO LUBRICATION IS NECESSARY.**

## SECTION 5

### WARRANTY INFORMATION

#### A. WARRANTY

For a copy of the commercial warranty covering your particular dryer(s), contact the distributor from whom you purchased the equipment and request dryer warranty form.

**NOTE:** Whenever contacting the factory for warranty information, be sure to have the dryer's model number and serial number available so that your inquiry can be handled in an expeditious manner.

#### B. RETURNING WARRANTY PARTS

All dryer or parts warranty claims or inquiries should be addressed to the factory. To expedite processing, the following procedures must be followed:

1. No parts are to be returned to the factory without prior written authorization.

**NOTE:** An Return Material Authorization (RMA) is valid for only sixty (60) days from date of issue.

- a. The RMA. Issued by the factory, as well as any other correspondence pertaining to the returned part (s), must be included inside the package with the failed merchandise.

2. Each part must be tagged with the following information:

- a. Model number and serial number of the dryer from which part was removed.
- b. Nature of failure (be specific).
- c. Date of dryer installation.
- d. Date of part failure.

3. The company returning the part(s) must clearly note the complete company name and address on the outside of the package.

4. **All** returns must be properly packaged to insure that they are not damaged in transit. Damage claims are the responsibility of the shipper.

**IMPORTANT:** No replacements, credits, or refunds will be issued for merchandise damaged in transit.

5. **All** returns should be shipped to the factory in such a manner that they are insured and a proof of delivery can be obtained by the sender.

6. Shipping charges are not the responsibility of the factory. All returns should be "prepaid" to the factory.

Any "C.O.D." or "COLLECT" returns will not be accepted. Shipping charges are not the responsibility of the factory. All returns should be "prepaid" to the factory. Any "C.O.D." or "COLLECT" returns will not be accepted

## **SECTION 6**

### **COMPONENT SYSTEM DESCRIPTIONS**

#### **A. BASKET/TUMBLER DRIVE SYSTEM**

The basket (tumbler) is supported and driven by eight (8) 11-inch diameter drive wheels. Two (2) of these wheels are attached to 50 mm. diameter idler shaft, while the other two (2) are attached to a 50 mm. diameter drive shaft. Each of the wheels is fastened to the shafts by a keyless locking bushing. The trantorque is made up of three pieces: an inner collar, an outer sleeve, and a locking nut. The inner and outer elements have matching opposite tapers. As a result, when the nut is tightened, the trantorque contracts onto the shaft and expands into the drive wheel locking the wheel onto the shaft. No key is required.

The idler and drive shafts are each supported by two- (2) 50 mm. diameter plummer block bearings. These bearings sit on slotted support channels and can be moved inward or outward by the adjustment bolts to raise or lower the basket (tumbler). The Drive shaft sticks out through the side of the dryer and has a sprocket No.60-3 Attached to it with taper lock bushing. This sprocket is connected to a helical geared motor The drive shafts is supported by two- (2) 50 mm. diameter plummer block bearings. These pillow blocks sit on a slotted platform, and they can be moved forward and back by loosening or tightening the bearing adjustment bolts. this movement is needed to maintain proper tension on the sprocket that run from the helical geared motor idler to the drive shaft.

The helical geared motor sits on an adjustable base so that the helical geared motor can be moved forward and back, allowing proper tension to be maintained on the sprocket.

#### **B. BASKET/TUMBLER**

The basket (tumbler) is made of 14-gauge stainless steel preferred panels, four (4) stainless steel ribs, and two (2) outer basket/tumbler rings made of rolled steel angle Iron that has turned

on a lathe for smoothness, The basket (tumbler) is a completely welded assembly so the perforated panels are not removable.

#### **C. AIR BLOWER DRIVE SYSTEM**

The impeller (fan) used in the DA-475 dryer is a 28-inch diameter forwardly Inclined squirrel cage impeller (fan) wheel. t spins in a counterclockwise direction looking at the back of the blower housing.

The impeller / fan shaft is mounted in two (2) 55 mm. diameter pillow block bearings, and the shaft is driven by two (2) BX-section V-belts connected to the blower motor.

The blower motor is mounted on an adjustable base. The motor position can be easily adjusted

so that proper tension can be maintained on the V-belts.

## D. SAFETY DEVICES

### 1. Load Door Switches

There are two (2) of these switches located under the main loading doors. These switches ensure that the doors are closed before the dryer can start. If the dryer is started when the load doors are open, the microprocessor controller (computer) L.E.D. display will show “door”

### 2. Lint Basket Switch

This switch ensures that the lint basket is closed before the dryer can start. This switch is located at the front of the dryer at the right side of lint basket. If the lint basket is open when the dryer is started, then the microprocessor controller (Computer) L.E.D. display will show “door”

### 3. Basket (tumbler) Hi-Limit Safety Thermostat

This disc temperature switch has a setting of 225 F. It is located below the basket (tumbler) on the temperature sensor bracket, along side the computer sensor, and is an automatic reset type of switch. Access to this switch is gained by sliding/pulling the lint basket/drawer completely out of the dryer.

This switch backs up the computer sensor and in case of a computer sensor malfunction will prevent the basket's (tumbler's) temperature from becoming excessive. If this switch trips, the gas flow to the burner box will be shut down; However, the basket (tumbler) will still rotate

### 4. Burner Box Hi-limit Safety Thermostat **(GAS DRYERS ONLY)**

This disc temperature switch has a setting of 330 F. It is located on the right side of the burner box, and is an automatic reset type of switch. This switch ensures that there is proper airflow through the burner box. Upon a low airflow condition, which ensures may be caused by a clogged lint screen, excessively long or blocked exhaust duct, or improper make-up air, the temperature in the burner box will increase tripping this switch. This will shut off the gas flow to the burner box; However, the basket (tumbler) will still run.

### 5. Sail Switch **(GAS DRYERS ONLY)**

The sail switch is located in the front top of the burner box. A sail switch consists of a round damper plate on a lever arm which is in contact with an electric switch. When the air blower comes on, it draws air through the gas burner. This creates a negative pressure inside the burner box, and this negative pressure pulls in the round damper and activates the sail switch. If there is an improper (low) airflow through the dryer, the sail switch damper will not pull in, preventing the heat from

Low airflow through the dryer will be caused by overly long or blocked exhaust ducting, lack of make-up air, or a clogged lint screen.

## E. STEAM DAMPER ACTUATOR SYSTEM

This system consists of a hinged damper plate, pneumatic piston, and 24-volt solenoid valve with a needle valve to control the speed of the piston actuation.

On a call for heat, a 24-volt signal is applied to the 3-way/2-position solenoid valve. This signal switches the valve so that compressed air is sent to the piston. The piston rod extends, pushing the hinged steam damper plate to the open position. This allows room air to be drawn through the hot steam coil and then through the basket (tumbler).

When the temperature set point has been reached, the 24-volt signal is removed from the solenoid valve, so that the solenoid valve blocks the air supply to the piston and the air in the piston is bled to the atmosphere. The spring in the piston now retracts the piston rod, closing the steam damper. The steam damper plate now covers the steam coil and allows room air to bypass the coil before entering the basket (tumbler) For a rapid cool down.

The steam damper plate should open and close slowly and smoothly. This speed can be modulated by adjusting the needle valve knob. Turning the knob clockwise restricts the compressed airflow and slows down the steam damper movement. counterclockwise adjustment speeds up the steam damper motion. Upon completion of adjustment, tighten the needle valve's locking nut.

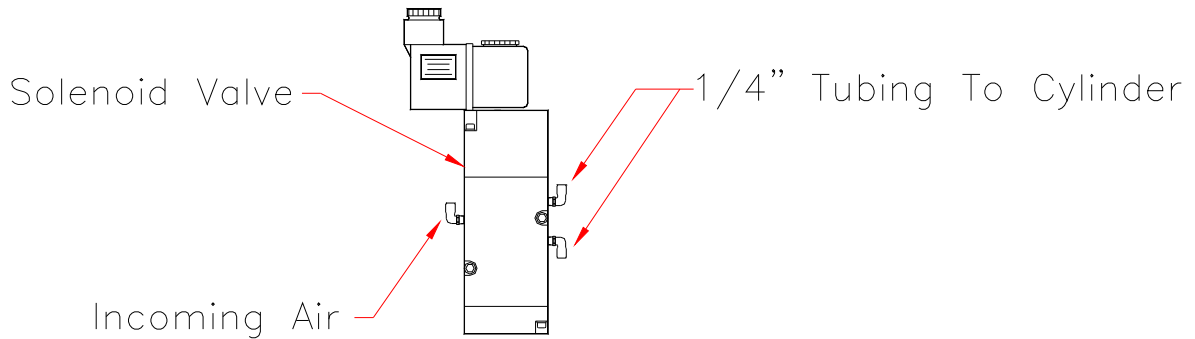

## F. DRIVE SYSTEM SOFT START

The DA-475 dryer is equipped with either a Series **154-A11NB OR 21B** soft start control. **ALL** soft start controls are factory preset. Re-adjustment should not be necessary.

### 1. Series 154-A11NB OR 21B Drive System Soft Start

#### Wiring

The **Series 154-A11NB OR 21B** is a motor controller and is used with an electromechanical motor starter. The controller is wired after the motor starter as shown in the **illustration below**.

The output side of the motor starter should be wired to the line terminals on the controller, (L1,L2,L3). The load terminals on the controller, (T1,T2,T3) then **Should be** wired to the motor.

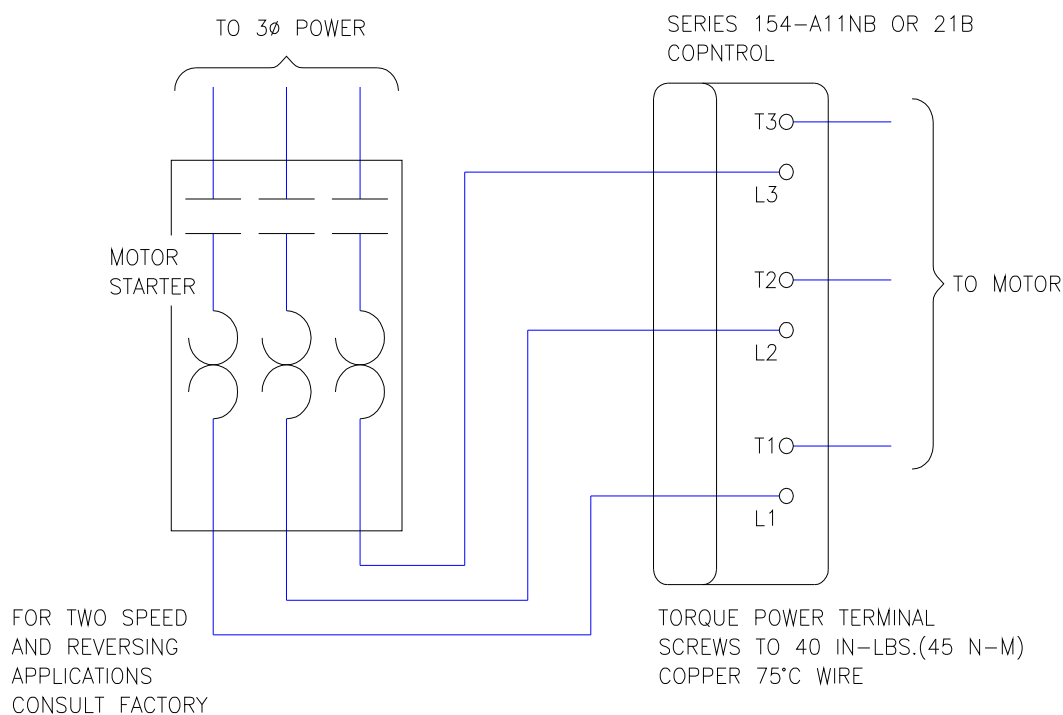

When the motor starter is turned on, 3-phase (3 $\phi$ ) power will be applied to the input to the controller. The controller will then ramp up the voltage to the motor. The duration of the ramp will

depend on the setting of the soft start adjustment. When the motor starter is turned off, the controller will reset and will be ready for the starter to be turned on again.

**NOTE: THE STARTER MUST REMAIN OFF FOR A MINIMUM OF 1/2 SECOND TO ALLOW THE CONTROLLER TO COMPLETELY RESET IF THE STARTER IS TURNED ON BEFORE THE CONTROLLER RESETS, AN ACCEPTABLE SOFT START MAY BE**



## ACHIEVED.

### Set Up

The single adjustment on the **Series 154-A11NB OR 21B** Determines the amount of starting voltage first applied to the motor. When rotated fully Counterclockwise, the lowest starting Voltage is obtained. As the adjustment is Rotated clockwise, the starting voltage is Increased. When rotated fully clockwise, The controller will produce approximately An across the line start. The motor will Receive full voltage within about one half (1/2) second.

To set up the controller for the best soft start:

- 1) Fill the basket (tumbler) with a normal size Load.
- 2) Rotate the adjustment fully counter clockwise. This will give the motor the lowest starting Voltage and the longest starting time.
- 3) Start the motor. When properly set, the Motor shaft should start to rotate when The start button is pushed. If the motor Does not start to rotate when the start Button is pushed but is delayed for several seconds, turn the motor off and rotate The adjustment in the clockwise direction. This will increase the starting voltage And decrease the starting time.
- 4) Restart the motor. Continue to readjust the setting until an acceptable start is Obtained-clockwise for a harder start-counterclockwise for a softer start.

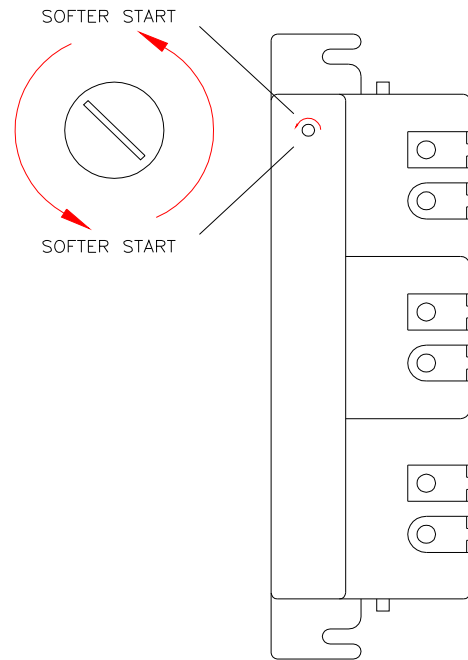

## **2. Series 154-A11NB OR 25 Drive System Soft Start**

The soft start mechanism is simply a voltage-limiting device. Therefore, to be capable of seeing just what is happening, connect the leads of a voltmeter to connections T2 and T3, as shown in **Figure 1**

Initial starting voltage should be 60 percent to 65 percent of motor nameplate voltage. Soft start time should be approximately 5 to 7 seconds, as indicated in **Figure 2**

The starting torque is dependent on the instantaneous RPM of the motor, which is Directly proportional to the voltage the motor receives, as shown in **Figure 3,**

If the starting voltage is too low, the motor will not have enough torque to turn the Basket (tumbler). Therefore, it is important that the starting voltage be high enough to Turn the basket (tumbler) and that the total starting time be short enough to reduce the Chance of overloading the system and blowing the fuses.

The 60 percent to 65 percent of the nameplate voltage for starting voltage and the 5 to 7 second soft start time were developed by testing with both a fully laded basket (tumbler) and an empty basket (tumbler). Therefore, any dryer adjusted as stated will operate properly with any size load up to the rated capacity.

**Figure 4** indicates the difference in the starting voltage necessary for Various size loads between empty and full.

FIG.1

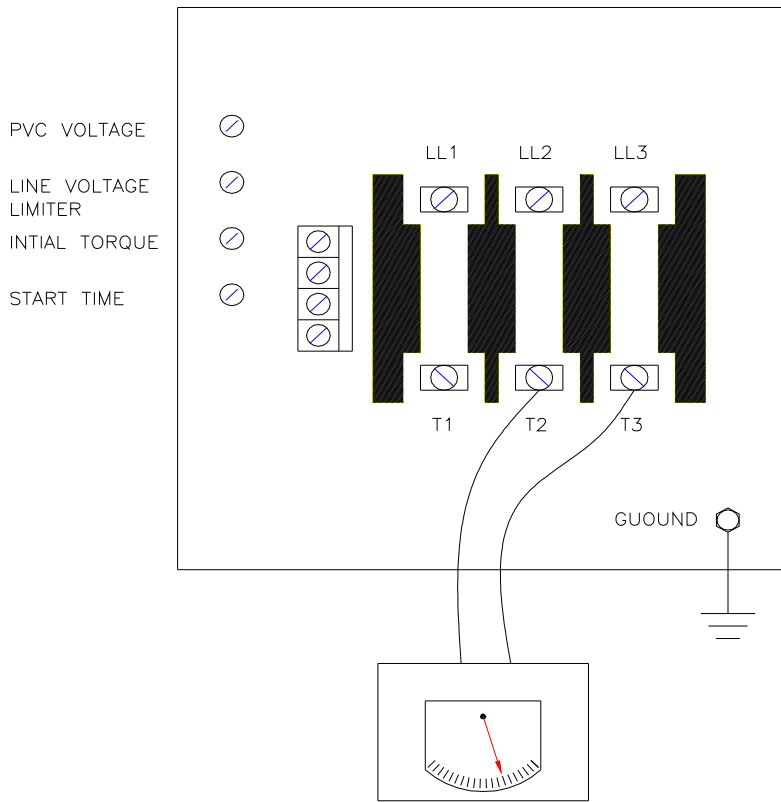

FIG.2

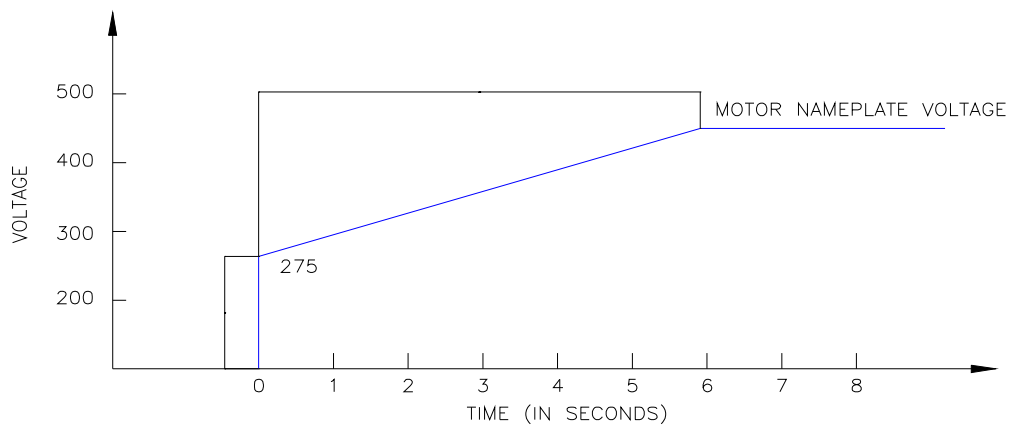

FIG.3

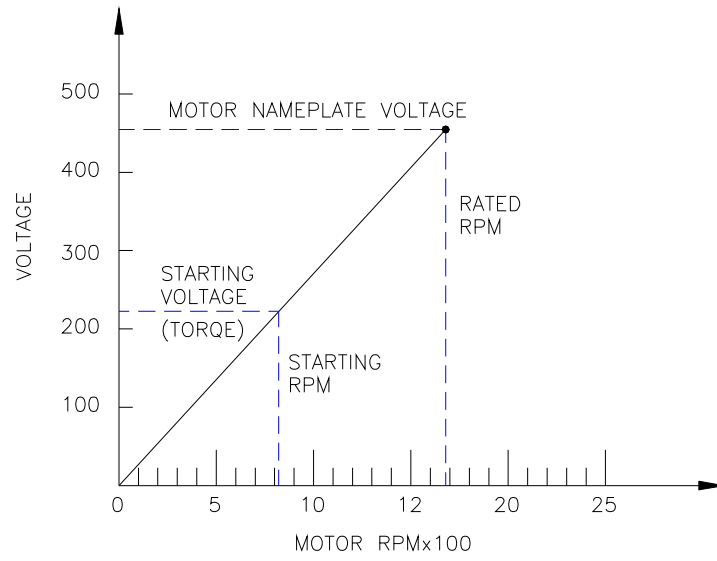
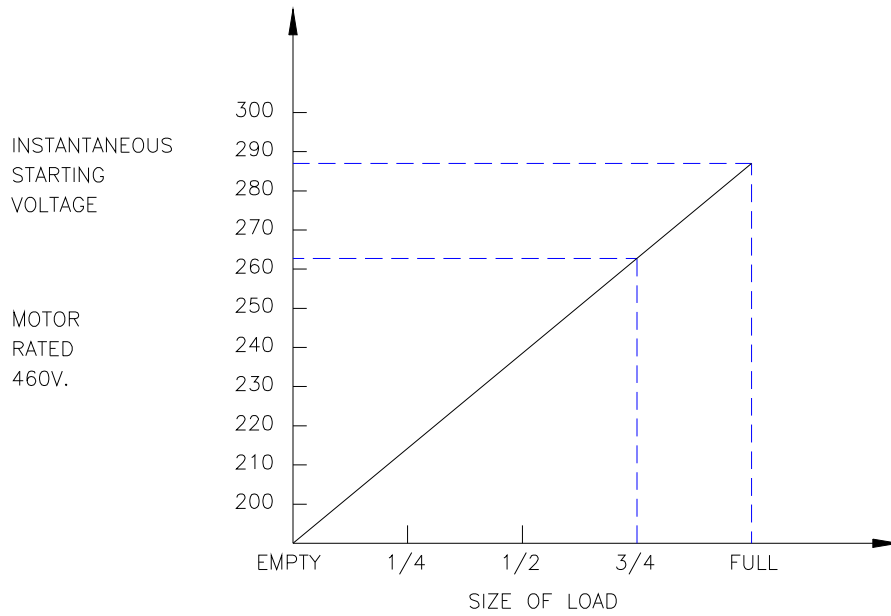

FIG.4



### 3. Adjustments for reduced voltage soft controllers

This procedure to be used with ALL Series 154-A11NB OR 21B OR 25 control styles.

To properly adjust a soft start controller to give a satisfactory start, two characteristics Of the motor and load **must be** considered. The frictional load determines the amount Of torque required to break-away or obtain initial movement of the motor and load. A System with a high frictional load will require a higher setting of the **START TORQUE** Adjustment than a system with little or no frictional load. Second, the amount of inertia In the system will determine the **START TIME** adjustment setting. Generally, systems With low inertia will require a long **START TIME** adjustment to give a satisfactory start, Whereas, systems with inertia may need only a very short **START TIME**. The softest Possible start will occur when the start time adjustment is set to maximum and the Initial torque adjustment is set at the point where the motor just starts the tumbler Moving when power is first applied.

#### a. **START TORQUE** Adjustment

The **START TORQUE** adjustment is factory preset for maximum torque (maximum Starting voltage).

- 1) Rotate the **START TIME** adjustment fully clockwise so that the longest starting Time is obtained.
- 2) Rotate the **START TORQUE** adjustment to midrange on the dial which will lower The starting torque.
- 3) Start the motor. If more or less torque is desired, turn off the power, and rotate The **START TORQUE** adjustment in the appropriate direction until an acceptable Soft start is obtained.

#### b. **START TIME** Adjustment

The **START TIME** adjustment range is ½ to 30 seconds. The higher the value of The **START TORQUE**, the shorter the duration of the overall time period.

- 1) During the **START TORQUE**, adjustment process, the **START TIME** was Adjusted for the longest start possible. If a shorter time is required, rotate the Adjustment counterclockwise.
- 2) Start the motor and determine if the soft start is acceptable.
  - a) If not, continue to rotate the **START TIME** adjustment until an acceptable Start is obtained.

## **SECTION 7**

### **TROUBLESHOOTING**

IMPORTANT: YOU MUST DISCONNECT and LOCKOUT THE ELECTRIC SUPPLY and THE GAS SUPPLY or THE STEAM SUPPLY BEFORE ANY COVERS or GUARDS ARE REMOVED FROM THE MACHINE TO ALLOW ACCESS FOR CLEANING, ADJUSTING, INSTALLATION, or TESTING OF ANY EQUIPMENT per OSHA ( Occupational Safety and Health Administration ) STANDARDS.

The information provided will help isolate the most probable component (s) associated With the difficulty described. The experienced technician realizes, however, that a Loose connection or broken/shorted wire may be at fault where electrical components are concerned...not necessarily the suspected component itself. Electrical parts should always be checked for failure before being returned to the factory.

**IMPORTANT:** When replacing blown fuses, the replacement **must be** of the exact rating as the fuse being replaced. The information provided **should not** be misconstrued as a handbook for use by an untrained person in making repairs

**WARNING: ALL SERVICE AND TROUBLESHOOTING SHOULD BE PERFORMED BY A QUALIFIED PROFESSIONAL OR SERVICE AGENCY.**

**WARNING: WHILE MAKING REPAIRS, OBSERVE ALL SAFETY PRECAUTIONS DISPLAYED ON THE DRYER OR SPECIFIED IN THIS MANUAL**

#### **A. No display...**

1. Service panel fuses blown or tripped breaker
2. Blown **FU1** fuse 1 or **FU2** fuse 2
3. Failed microprocessor controller (computer)

#### **B. Drive motor not operating (does not start)...**

- \* Microprocessor controller (computer) relay output indicator (either) forward "FWD" or reverse "REV" is on
1. Blown drive motor contactor fuse (s)
  2. Failed drive motor contactor
  3. Failed drive motor
  4. Failed soft start
- \* Microprocessor controller (computer) relay output indicator (neither) forward "FWD" or reverse "REV" go on

1. Failed microprocessor controller (computer)

**C. Drive motor operates in one direction only...stops and restarts in same**

\* Appropriate microprocessor controller (computer) relay output indicator is on

1. Failed reversing contactor (relay)

\* Appropriate microprocessor controller (computer) relay output indicator is off

1. Failed microprocessor contactor (computer)

**D. Drive motor operates okay for a few minutes and then either repeatedly or Occasionally trips the overload protector...**

**NOTE:** WHEN THE OVERLOAD PROTECTOR TRIPS. THE MICROPROCESSOR CONTROLLER (COMPUTER) L.E.D. DISPLAY WIL READ "door"

1. Motor is overheating
  - a. Motor air vents clogged with lint
  - b. Low voltage to motor
  - c. Failed motor
  - d. Basket (tumbler) is binding...check for an obstruction
  - e. Failed idler bearings or tumbler bearings
  - f. Sprocket and V-belts are too tight
2. Failed overload protector

**E. Impeller/fan motor not operating (does not start)**

\* Microprocessor controller (computer) "MTR" relay output indicator is on

1. Blown blower (impeller/fan) motor contactor fuse (s)
2. Failed blower (impeller/fan) motor contactor (relay)
3. Failed blower (impeller/fan) motor

\*Microprocessor controller (computer) "MTR" relay output indicator is off

1. Failed microprocessor controller (computer)

**F. Blower (impeller/fan) motor operates okay for a few minutes and than either Repeatedly or occasionally trips the overload protector...**

NOTE: WHEN THE OVERLOAD PROTECTOR TRIPS, THE MICROPROCESSOR CONTROLLER (COMPUTER) L.E.D. DISPLAY WILL READ, "door".

1. Motor is overheating
  - a. Motor air vents clogged with lint
  - b. Low voltage to motor
  - c. Failed motor
  - d. Failed impeller/fan drive bearings
  - e. Sprocket and V-belts are too tight
2. Failed overload protector

**G. Both drive motor and blower (impeller/fan) motor are not operating...microprocessor controller (computer) L.E.D. motor indicator dots and the "MTR" Relay output and forward "FWD" or reverse "REV" L.E.D. indicators are on...**

1. Blown drive motor and blower motor fuses
2. Failed motors (both blower and drive)

**H. Both drive motor and blower (impeller/fan) motor are not operating...microprocessor controller (computer) L.E.D. motor indicator dots and the "door" L.E.D. indicator are on but relay output L.E.D. indicators are off (microprocessor controller (computer) L.E.D. display does not read "door"**

1. Failed microprocessor controller (computer)

**I. Both drive motor and blower (impeller /fan) motor run a few minutes then stop microprocessor controller (computer) L.E.D. display continues to read time or percent of extraction and all indicator dots are off...**

1. Fault in main door switch circuit
  - a. One (1) of the main door switches is out of adjustment
  - b. Loose connection somewhere in the door switch circuit
2. Fault in lint drawer switch circuit
  - a. Lint drawer switch out of proper adjustment
  - b. Loose connection in the lint drawer switch circuit

**J. Microprocessor controller (computer) L.E.D. display reads "dSFL" Continuously and the buzzer (tone) sounds every 30 seconds....**



1. Fault in microprocessor temperature sensor
  - a. Failed microprocessor temperature sensor
  - b. Blown “dSFL” 1/8-amp fuse on the microprocessor controller (computer)
  - c. Failed microprocessor controller (computer)
  - d. Broken wire or connection somewhere between the microprocessor controller (computer) and the microprocessor temperature sensor

**K. Microprocessor controller (computer) display reads “door” and the microprocessor controller “DOOR” L.E.D. indicator is off...**

1. Fault (open circuit) in main door/lint drawer switch circuit
  - a. Lint drawer not closed all the way
  - b. Lint drawer switch is out of proper adjustment
  - c. Failed lint drawer switch
  - d. One (1) of the main door switches has failed
  - e. One (1) of the main door switches contact magnets is either missing or broken
  - f. Failed door switch relay
  - g. Broken wire/connection in main door or lint drawer switch circuit
2. Failed 24 VAC step down transformer
3. Drive and/or blower (impeller/fan) motor thermal overload reset has tripped
4. Blown 24 VAC control circuit fuse (fuse3)

**L. Microprocessor controller (computer) L.E.D. display reads “door” and the microprocessor controller “DOOR” L.E.D. indicator is on...**

1. Failed microprocessor controller (computer)

**M. Microprocessor controller (computer) will not accept any keyboard (touchpad) entries, i.e., display reads “FILL” and when keyboard (touchpad) entries are selected, the display continues to read “FILL”...**

1. Failed keyboard label (touchpad) assembly
2. Failed microprocessor controller (computer)

**N. Microprocessor controller (computer) will only accept certain keyboard (touchpad) entries...**

1. Failed keyboard label (touchpad) assembly

**O. Microprocessor controller (computer) locks up and L.E.D. display reads erroneous message (s) or only partial segments...**

1. Transient power voltage (spikes)...disconnect power to dryer, wait one (1) minute and reestablish power to dryer. If problem is still evident:
  - a. Failed microprocessor controller (computer)
  - b. Failed keyboard label (touchpad) assembly

**P. Dryer stops during a cycle, microprocessor controller (computer) buzzer (tone) sounds for 5 seconds, L.E.D. display reads “dSFL” for approximately 30 seconds and then return to “FILL”...**

1. Loose connection somewhere between the microprocessor controller (computer) and the microprocessor temperature sensor

**Q. Dryer stops during a cycle, microprocessor controller (computer) buzzer (tone) sounds for a few seconds, and then the microprocessor controller (computer) L.E.D. display returns to “FILL”...**

1. Loose connection somewhere in the main power circuit to the microprocessor controller (computer)

**R. Microprocessor controller (computer) L.E.D. display reads “SEFL”...**

1. Microprocessor controller (computer) program (Program Location 2) is set incorrectly in the active mode (“Sen”) where dryer is not equipped with the **optional** rotation sensor program **must be** set as “Sen”
2. Rotational sensor circuit (optional) failure...fault somewhere in the basket (tumbler) rotation or circuit
  - a. Basket (tumbler) not rotating
    - 1) Broken basket (tumbler) drive V-belt(s)
    - 2) Failure in drive motor circuit...refer to part B, Part C, and Part D on
  - b. Bad rotation sensor
  - c. Broken wire or connection between rotation sensor and microprocessor controller (computer)

**S. Microprocessor controller (computer) L.E.D. display reads “Hot”...**

1. Possible overheating condition...microprocessor controller (computer) has sensed a temperature which has exceeded 225° F

“Hot” display will not clear until temperature sensed has dropped to 225° F or lower and the microprocessor controller (computer) is manually reset by pressing the CLEAR/STOP” key

**T. Gas heating unit is not operating (no heat)... no spark at burner area when the dryer is First started, and both the heat indicator dot and the “HEAT” relay output L.E.D. are on**

1. Fault in sail switch circuit
  - a. Sail switch is out of adjustment or has failed
  - b. Sail switch damper is not closing or is fluttering
    - 1) Lint drawer/screen is dirty
    - 2) Restriction in exhaust
    - 3) No exhaust air flow
2. Fault in burner hi-limit circuit or thermostat
3. Fault in 225° hi-limit switch or thermostat
4. Failed direct spark ignition (DSI) module
5. Failed DSI igniter/flame-probe assembly

**U. Heating unit (GAS MODELS or STEAM MODELS) is not operating (no heat) and the microprocessor controller (computer) L.E.D. heat indicator dot is on but the “HEAT” relay output L.E.D. is not on...**

1. Failed microprocessor controller (computer)

**V. No heat (GAS MODELS)...igniter sparks, burner goes on and off right away**

1. DSI igniter/flame-probe out of adjustment...reposition closer to the flame area
2. Sail switch is fluttering
  - a. Lint drawer/screen is dirty
  - b. Restriction in exhaust duct work
  - c. Blower impeller/fan going in the wrong direction
3. Insufficient make-up air

4. Failed igniter/flame-probe assembly
5. Failed direct spark ignition (DSI) module
6. Failed gas valve

**W. No heat (STEAM MODELS ONLY)...both microprocessor controller (computer) L.E.D. heat indicator dot and the "HEAT" relay output L.E.D. are on...**

1. Fault in 225° hi-heat (limit) switch circuit or thermostat
2. No (external) compressed air to steam damper... 80 PSI required
3. Failed steam damper 24 VAC pneumatic solenoid valve
4. Failed steam damper piston
5. Steam damper stuck closed

**X. Dryer operates but is taking too long to dry...**

1. Exhaust duct work run too long or is undersized...back pressure cannot exceed .3 inches W.C.
2. Restriction in duct work...cheat duct from dryer all the way to the outdoors
3. Low and/or inconsistent gas pressure (GAS MODELS ONLY)
4. Insufficient make-up air
5. Poor air/gas mixture at burner-yellow or poor flame pattern...adjust gas burner air adjustment shutters (GAS MODELS ONLY)
6. Lint drawer/screen not being cleaned on a regular basis or often enough
7. Extractors (washers) not performing properly
8. Sail switch is fluttering...restriction in exhaust (GAS MODELS ONLY)
9. Failed microprocessor controller (computer)...temperature calibration is inaccurate
10. Failed microprocessor temperature sensor...calibration is inaccurate
11. Failed burner hi-limit (GAS MODELS ONLY)
12. Failed 225° hi-limit (thermostat)
13. Steam damper system not functioning properly (STEAM MODELS ONLY)
  - a. Steam damper sticking closed
  - b. Leak in pneumatic system

**Y. Excessive noise and/or vibration...**

1. Dryer not leveled properly
2. Impeller (fan) out of balance
  - a. Excessive lint build up on impeller (fan)...check air jet
  - b. Failed impeller (fan)
3. Loose motor mount
4. Failed idler bearings and/or tumbler bearings
5. V-belt(s) either too tight or too loose
6. Soft start device not adjusted properly
7. Tumbler drive wheels are worn or loose
8. Set screws of the tumbler drive shaft bearings are loose
9. Failed motor bearings
10. Drive wheel transtorque is loose

**Z. Scrapping or rubbing noise in basket (tumbler) area or around front or rear panels...**

1. Check for object(s) caught somewhere in basket (tumbler)
2. Mis-adjusted thrust wheel(s)
3. Failed thrust wheel (s)

**AA. Basket (tumbler) jumps or makes excessive noise when dryer is first started or between forward and reverse cycles**

1. Soft start out of proper adjustment

**BB. Blower (impeller/fan) air jet does not activate at the end of cooling cycle \*With microprocessor controller (computer) "A JET" relay output L.E.D. on**

1. Fault in compressed air supply
2. Failed air jet

\*With microprocessor controller (computer) "A JET" relay output L.E.D. off

1. Failed microprocessor controller (computer)

## **SECTION 8**

### **PARTS MANUAL INFORMATION**



## Parts List

Item	Part No.	Qty.	Description
1	A2-S450-002	1	Panel, Front top
2	A2-S450-003	1	Door, Left front
3	A2-S450-004	1	Door, right front
4	A2-S450-005	1	Door, basket front Top
5	A2-S450-006	1	Door, basket front Lower
6	A2-S450-038	1	Door control, Top
7	A2-S450-039	1	Door control, EDG and Electrical
8	A2-S450-040	1	Door, Air supply
9	A2-S450-037	1	Panel, Right Lower front
10	A2-S450-011	1	Panel, Tilt Safety Guard, font
11	A2-S450-012	1	Door, lint filter access
12	A2-S450-013	1	Drawer lint filter
13	A2-S450-014	1	Panel, front lower left frame
14	A2-S450-015	1	Panel, front lower right frame

## Parts List

Item	Part No.	Qty.	Description
15	A0-A003-012	2	Door glass
16	A2-S450-016	1	Door, Left front (Lower)
17	A2-S450-017	1	Door, right front (Lower)





## Parts List

Item	Part No.	Qty.	Description
1	A2-S450-069	1	Filter For Steam
2	A0-E012-009	4	Filter for fan
3	A0-E012-001	2	Fan, Cooling
4	A2-S450-010	1	Panel, right Lower front
5	A2-S450-020	2	Panel, Right middle
6	A2-S450-010	1	Panel, right Lower front
7	A2-S450-038	1	Door control, Top
8	A2-S450-039	1	Door control, EDG and Electrical
9	A2-S450-040	1	Door, Air supply



## Parts List

Item	Part No.	Qty.	Description
1	A2-S450-033	1	Left panel, Top
2	A2-S450-034	1	Left middle panel assembly, (left)
3	A2-S450-035	1	Left middle panel assembly, (right)
4	A2-S450-029	1	Lower panel assembly, left
5	A2-S450-030	1	Panel, Tilt safety Guard, left Lower
6	A2-S450-031	1	Rear panel assembly, lower
7	A2-S450-032	1	Rear cover, lower
8	A2-S450-026	1	Rear shuttle – Left panel
9	A2-S450-027	1	Rear shuttle – Right panel
10	A2-S450-028	1	Rear shuttle – Main panel
11	A2-S450-024	1	Door, Left Rear
12	A2-S450-025	1	Door, right Rear
13	A2-S450-023	1	Door, right Rear (Lower)
14	A2-S450-022	1	Panel, Rear top

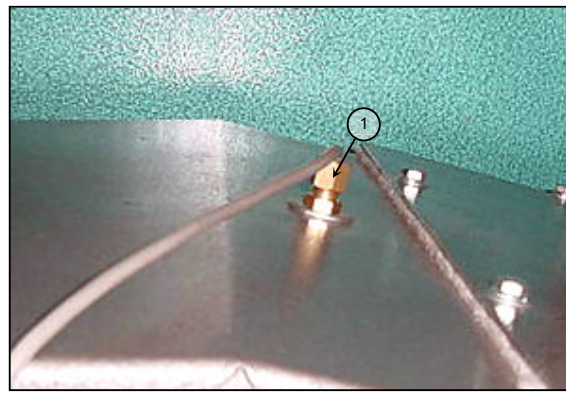
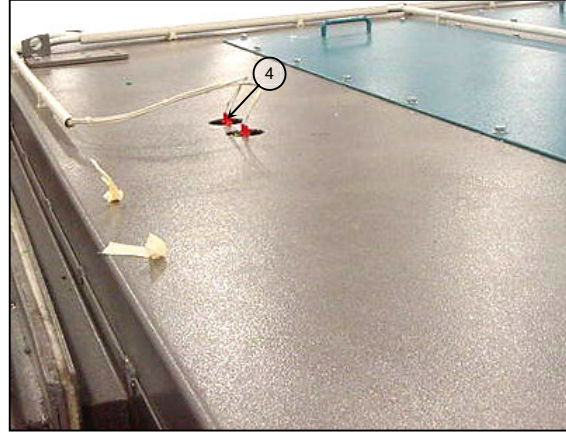

## Parts List

Item	Part No.	Qty.	Description
1	A0-E027-010	1	Temperature probe
2	A0-E016-001	1	Thermostat
3	A0-E016-011	1	Thermostat
4	A0-E016-013	1	Thermostat
	A0-E016-010	1	Thermostat e spray
5	A0-E040-008	1	Solenoid water valve

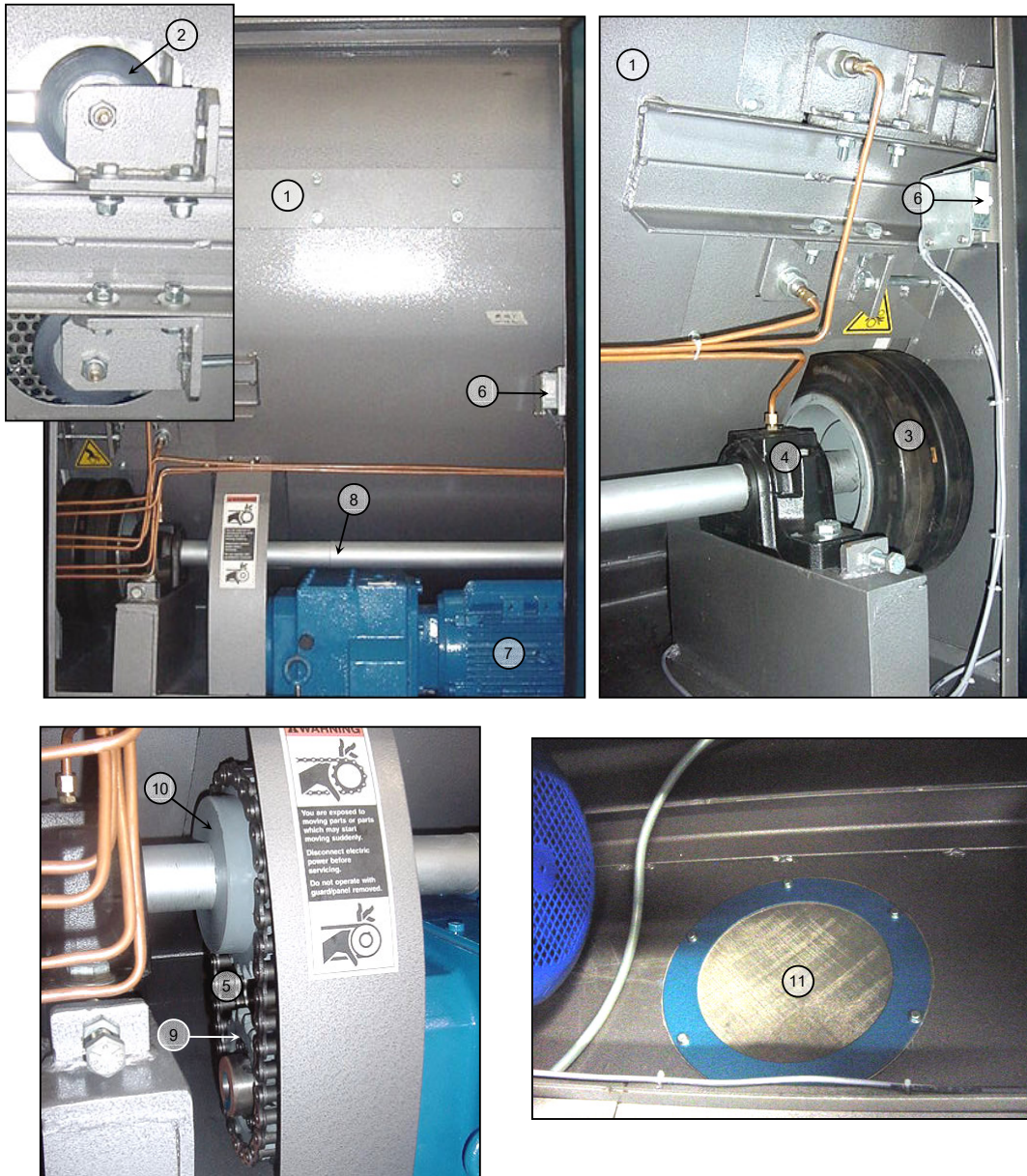

## Parts List

Item	Part No.	Qty.	Description
1	A2-S450-001	1	Assembly, shell
2	A0-A016-004	8	Guide wheel basket
	A0-A004-147	16	Ball Bearing
3	A0-A016-002	8	Wheel assembly

# Parts List

Item	Part No.	Qty.	Description
4	A0-TSA01-169	4	Housing
	A0-TSA01-067	4	Bearing
	A0-TSA01-035	4	Sleeve
	A0-TSA01-034	4	Seal
	A0-A007-020	-	Locating Rings set
5	A0-A051-030	1	Triple chain
6	A0-E011-022	2	Switch, Limit momentary
7	A0-TSE01-083	1	Helical Geared motor
8	A0-M011-033	1	Drive shaft basket
9	A0-M001-050	1	Triple Sprocket
10	A0-M001-051	1	Triple Sprocket
11	A2-S450-068	1	Fresh air Filter

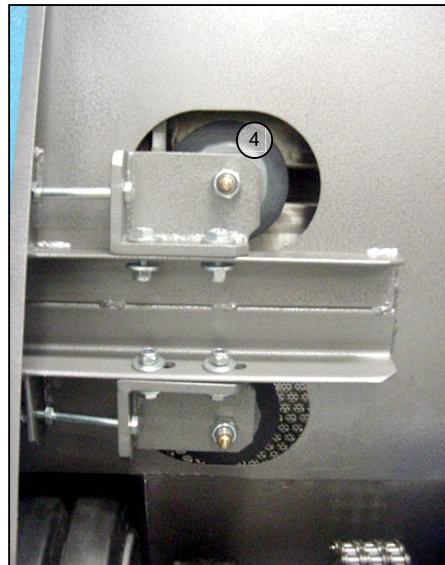
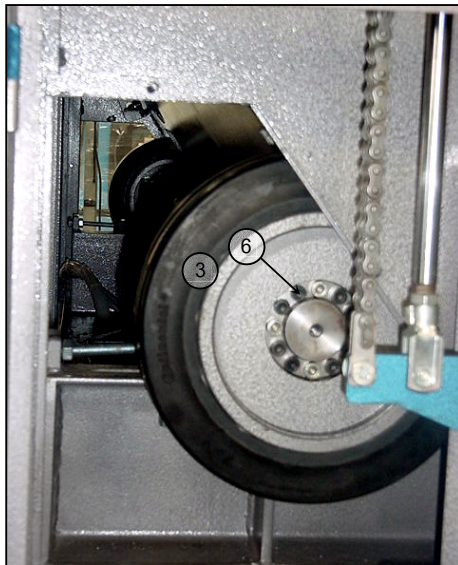
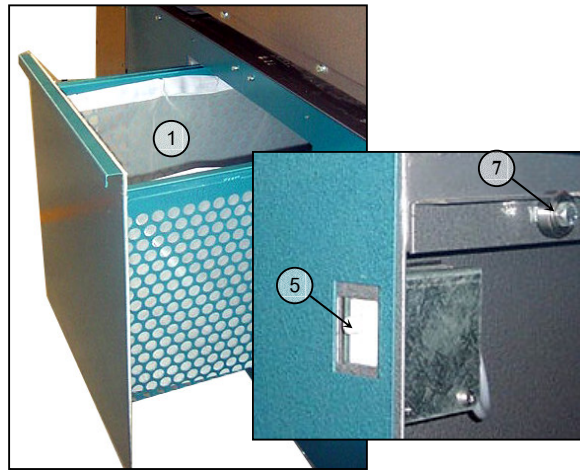
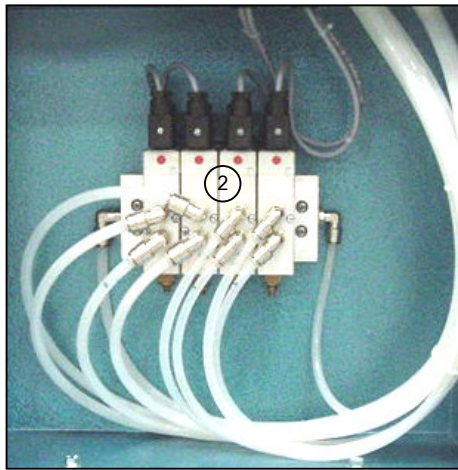

## Parts List

Item	Part No.	Qty.	Description
1	A2-S450-043	1	Filter
2	A0-P005-057	1	Air solenoid valve
3	A0-A016-002	8	Wheel assembly
4	A0-A016-004	8	Guide wheel basket
	A0-A004-147	16	Ball Bearing
5	A0-E011-022	1	Switch, Limit momentary
6	A0-TSA01-025	8	Sleeve hup wheel basket
7	A0-A004-038	12	Ball Bearing

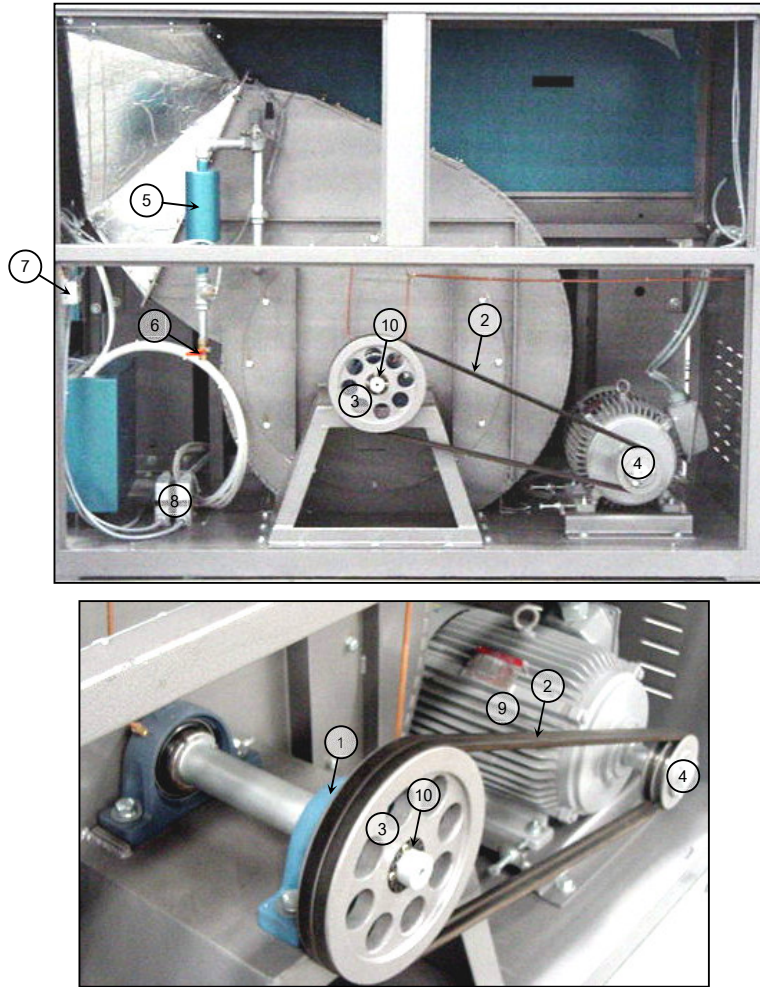

## Parts List

Item	Part No.	Qty.	Description
1	A0-A004-042	1	Y-Bearing plummer block units+Housing
2	A0-A002-051	2	V-Belt
3	A0-M008-110	1	Blower Pulley
4	A0-M008-109	1	Blower Pulley Motor
	A0-M009-050	1	Motor sheave bushing
5	A0-P005-119	1	Diaphragm valve
6	A0-A022-003	1	Gate valve
7	A0-E011-022	1	Switch, Limit momentary
8	A0-E055-024	2	Multipole wall type connector
9	A0-TSE01-080	1	Motor
10	A0-M009-078	1	Sleeve power lock

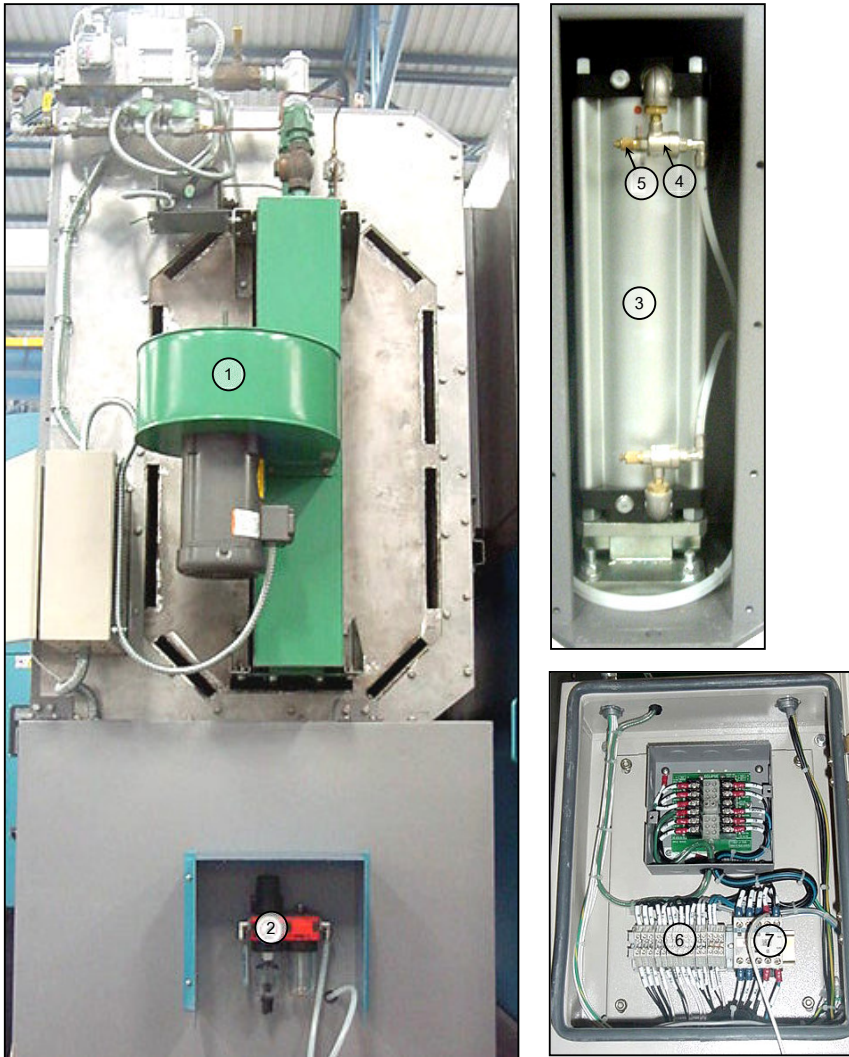

## Parts List

Item	Part No.	Qty.	Description
1	A0-E062-002	1	Burner, Gas (Air Heat)
	A0-E062-002/01	1	Ball valve
	A0-E062-002/02	1	Main gas valve
	A0-E062-002/03	1	Pressure sensor switch
	A0-E062-002/04	1	Regulator pilot line
	A0-E062-002/05	1	Pilot line valve
	A0-E062-002/06	1	Ignitor
	A0-E062-002/07	1	Burner duct housing



# Parts List

Item	Part No.	Qty.	Description
1	A0-E062-002/08	1	Burner housing
	A0-E062-002/09	1	Blower housing
	A0-E062-002/10	1	Blower fan
	A0-E062-002/11	1	Motor
2	A0-P004-002	1	Regulator
3	A0-TSP01-009	4	Air Cylinder
4	A0-P008-002	8	Quick Exhaust valve
5	A0-P006-010	8	Silencer
6	A0-E021-043	-	Terminal
7	A0-E004-011	1	Magnetic

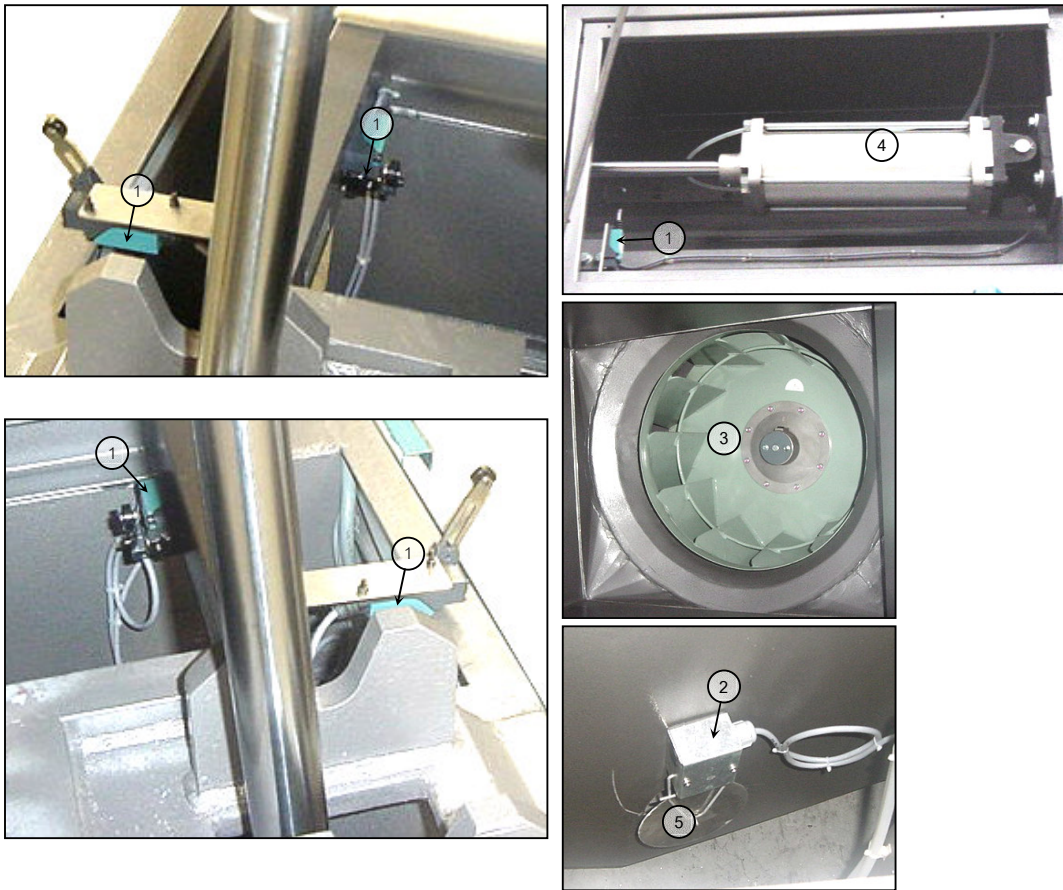

## Parts List

Item	Part No.	Qty.	Description
1	A0-E011-018	1	Limit switch variable length
2	A0-E014-001	1	Micro switch
3	A0-TSE01-079	1	Fan wheel model
4	A0-P003-031	1	Air cylinder
5	A2-S450-059	1	Flap filter

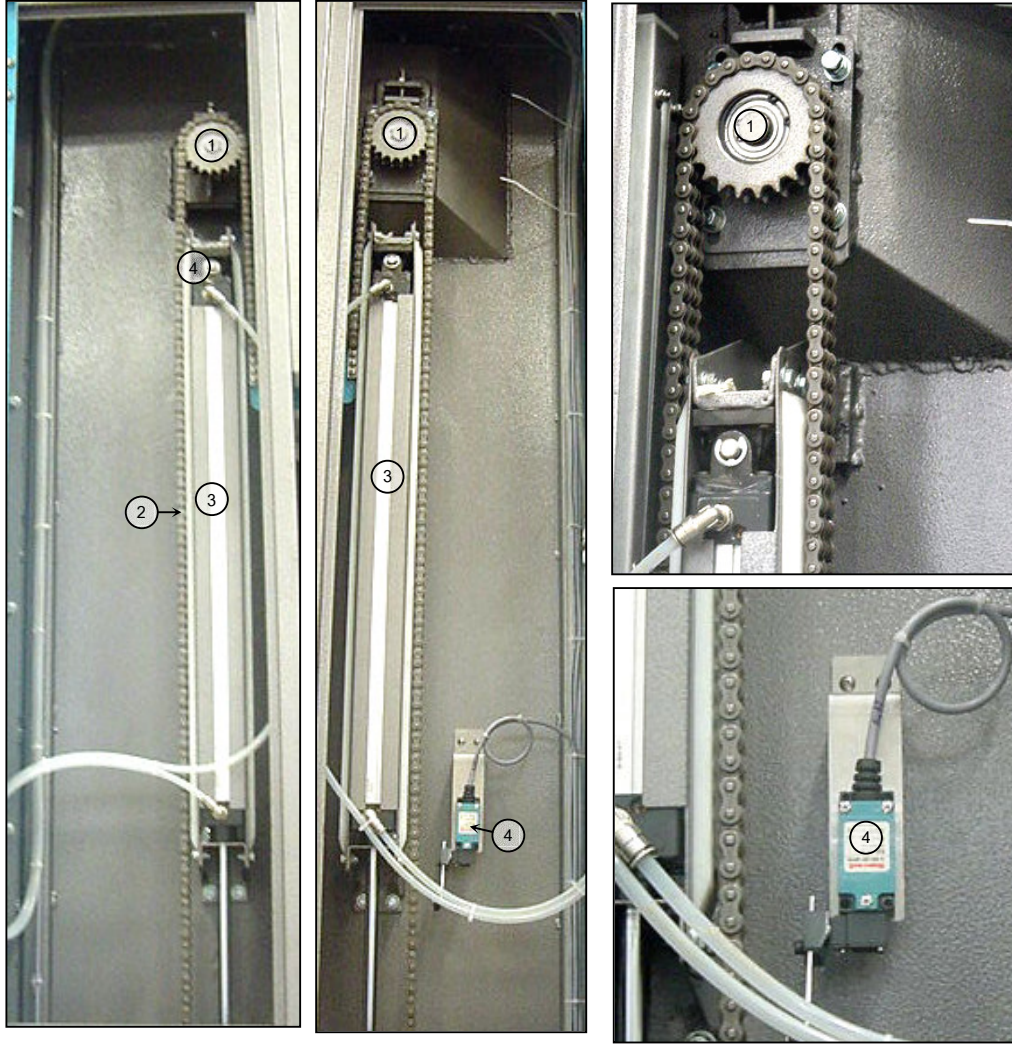

## Parts List

Item	Part No.	Qty.	Description
1	A0-TSM01-004	2	Double Sprocket
2	A0-A051-018	2	Double chain
3	A0-TSP01-202	2	Air Cylinder
4	A0-E011-018	1	Limit switch variable

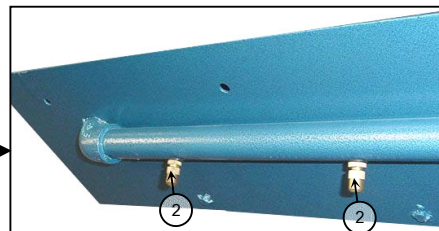
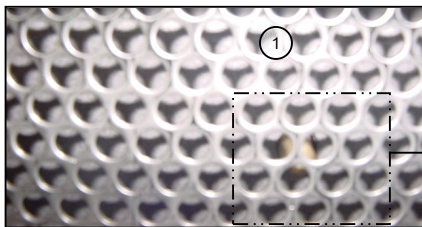

## Parts List

Item	Part No.	Qty.	Description
1	A2-S450-042	1	Basket dryer
2	A0-A095-050	5	Nozzle, spray
3	A0-A013-002	-	Lock
4	A0-A029-005	-	Hinge, off set panel door

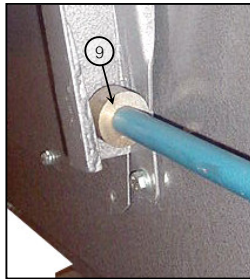
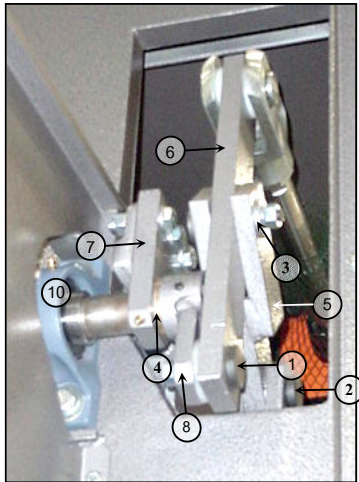

## PARTS LIST

Item	Part No.	Qty.	Description
1	A2-S450-060	1	Pin
	A0-TSE01-254	1	Bush
2	A2-S450-061	1	Pin
	A0-TSE01-253	2	Bush, Fixed Bracket
	A0-TSE01-254	1	Bush, Support Bracket fixed end
3	A2-S450-062	1	Pin, Arm-Support Bracket
	A0-TSE01-253	2	Bush-Support Bracket
	A0-TSE01-254	1	Bush, Arm
4	A2-S450-063	1	Bush, Swivel Bracket
5	A2-S450-064	1	Support Bracket
6	A2-S450-065	1	Arm, Bracket
7	A2-S450-066	1	Bush, Swivel Bracket
8	A2-S450-067	1	Shaft Bracket
9	A2-S450-036	2	Bush, Shoulder Brass
10	A0-A004-097	2	Y-Bearing plummer block units+Housing

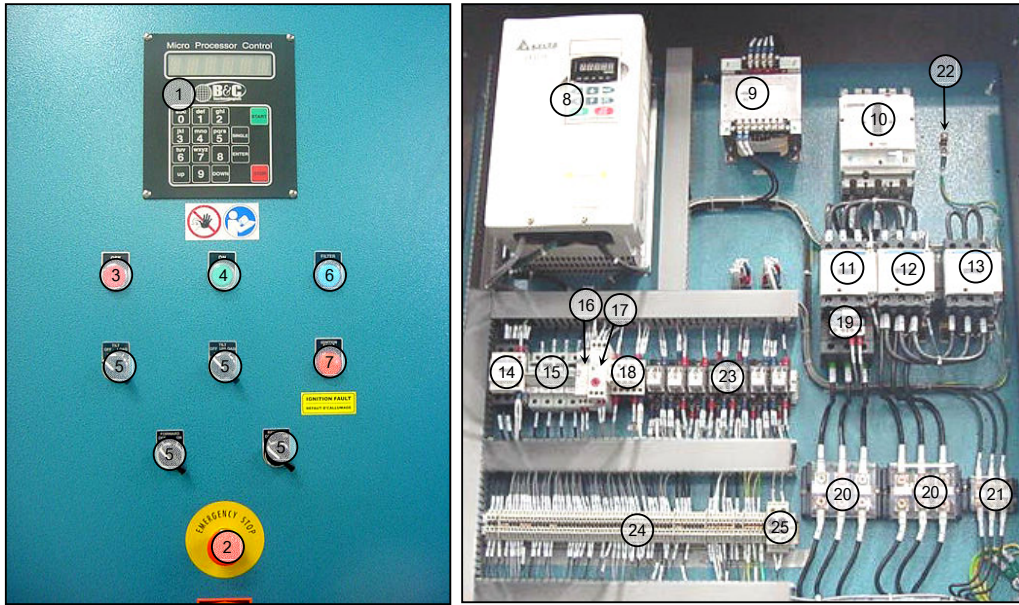

## Parts List

Item	Part No.	Qty.	Description
1	A0-E007-004	1	EDG Dryer control
2	A0-E032-018	1	Emergency Stop
3	A0-E032-007	1	Push button s.w.
4	A0-E032-009	1	Push button switch
5	A0-E028-006	4	Multi-Step Switch
6	A0-E035-021	1	Pilot light
7	A0-E035-019	1	Pilot light for over load
8	A0-E001-061	1	Inverter
9	A0-E006-032	1	Transformer
10	A0-E010-005	1	Circuit breaker
11	A0-E004-005	1	Magnetic Contactor
12	A0-E004-005	1	Magnetic Contactor
13	A0-E004-005	1	Magnetic Contactor
14	A0-E004-002	1	Magnetic Contactor

# Parts List

Item	Part No.	Qty.	Description
15	A0-E051-012	2	Fuse 4A
	A0-E051-007	1	Fuse 6A
16	A0-E031-009	1	Timer Coil
17	A0-E031-019	1	Watch dog timing relay
18	A0-E024-007	1	Auxiliary contact
	A0-E024-005	1	Auxiliary contact
19	A0-E025-028	1	Over Load
20	A0-E021-028	2	Terminal
21	A0-E021-025	1	Terminal
22	A0-E055-001	1	Connector, Ground Lug
23	A0-E009-001	6	Relay
	A0-E009-020	6	Socket Relay
24	A0-E021-043	-	Terminal
25	A0-E022-001	2	Plug fuse